



TEMPERATURE

- 8-9°C Vini bianchi leggeri e vini frizzanti, ad esempio, vini bianchi dolci da dessert
- 9-12°C Fino Sherry
- 10-11°C Vini bianchi pieni e frizzanti, come Champagne, Cremant e Cava
- 12-13°C Vini bianchi corposi, come Chardonnays, Bourgogne champagne d'annata, così come vini da dessert quali il Sauternes e l'Eiswein
- 14°C Porto
- 14-15°C Vini rossi giovani chiari come, Beaujolais e Pinot Nero
- 16-17°C Giovani e promettenti vini rossi come, Bourgogne, Saint Emilion, Pomerol, Chianti e Barbaresco
- 18-19°C Vini rossi corposi e maturi come, Rhône, Bor deaux Grand Cru, Barolo e Rioja Gran Reserva

- 8-9°C *Light white and sparkling wines e.g. sweet white dessert wines*
- 9-12°C *Fino Sherry*
- 10-11°C *Heavy white and sparkling wines e.g. Champagne, Cremant and Cava*
- 12-13°C *Full-bodied white wine e.g. Chardonnay, Bourgogne and vintage champagnes, as well as dessert wines such as Sauterne and Eiswein*
- 14°C *Port*
- 14-15°C *Light young red wines e.g. Beaujolais and ordinary Pinot Noir*
- 16-17°C *Young complex red wines e.g. Bourgogne, Saint Emilion, Pomerol, Chianti and Barbaresco*
- 18-19°C *Heavy, full-bodied and mature red wines e.g. Rhône wines, Bor deaux Grand Cru Classé, Barolo and Rioja Gran Reserva*



FILTRO A CARBONE: Dispositivo interno a carboni attivi che elimina i cattivi odori.
CHARCOAL FILTER: Internal filters with active carbons to avoid the bad smells.

Cantine frigo multizona

La serie Wine di cantine frigo multizona, è la preferita dai clienti per la capacità di soddisfare ogni esigenza di immagazzinamento di vino.

Una discreta porta vetro fumè con filtro UV, protegge il vino dai raggi del sole. Il compressore a basse vibrazioni ed i ripiani regolabili in legno assicurano che il vino venga conservato correttamente e indisturbato dal funzionamento della vetrina stessa. Nel complesso, la serie Wine, garantisce un risparmio energetico e una soluzione rispettosa dell'ambiente.

Multizone wine cabinets

The Wine series of MultiZone wine cabinets, is a customer favorite that honors every requirement for ideal storage of wine.

A discreet, smoked glass door with UV filter protects wine from rays of the sun. The low vibration compressor and adjustable wooden shelves ensure that wine is stored correctly and undisturbed by cabinet operation. Overall, the Wine series, ensures energy-saving and environmentally friendly solution.

Le 5 regole importanti per la conservazione

Il vino è un prodotto vivo e sensibile che richiede una delicata conservazione per salvaguardare le migliori condizioni per la sua maturazione ed invecchiamento.

TEMPERATURA: La temperatura ideale di conservazione del vino è circa 10-14°C, che dovrebbe essere costante.

UMIDITÀ: Un livello di umidità compreso tra il 50-75% è essenziale per mantenere la tenuta del tappo di sughero, e quindi la sua efficienza a mantenere l'aria fuori dalla bottiglia.

OSCURITÀ: La bottiglia non offre alcuna protezione contro i raggi diretti del sole, ed in particolare contro la luce ultravioletta che può essere dannosa per il vino. Di conseguenza, il vino deve essere conservato al buio e protetto in modo sicuro contro i raggi UV.

VIBRAZIONI: Se il vino è esposto a ripetute vibrazioni, queste disturbano lo sviluppo biochimico del vino. Le vibrazioni sono spesso il motivo per cui alcuni dei migliori e più raffinati vini non riescono a raggiungere il loro gusto ottimale.

VENTILAZIONE: Ventilazione e circolazione continua dell'aria sono di fondamentale importanza per evitare la formazione di odori sgradevoli.

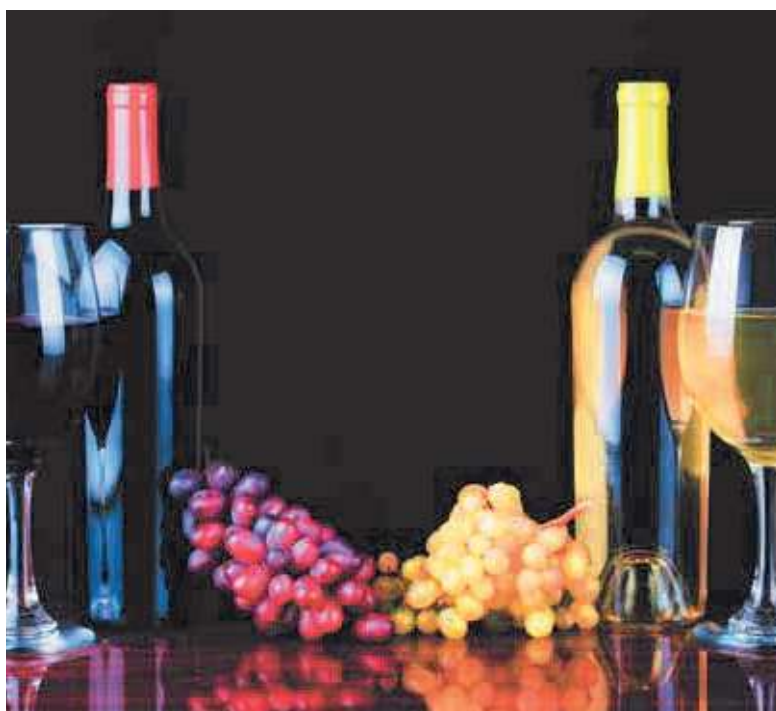

The 5 important rules for storage

Wine is a living and sensitive product which demands gentle storage to safeguard the best conditions for its maturation and development.

TEMPERATURE: The ideal storage temperature for wine is about 10-14°C which should be constant.

AIR HUMIDITY: A humidity level of between 50-75% is essential to maintain the cork's sealing effect, and thereby its efficiency at keeping air out of the bottle.

DARKNESS: The bottle offers no protection against direct sunlight, and ultraviolet light in particular can be harmful to wine.

Accordingly, wine should be stored in darkness safely protected against UV radiation.

VIBRATION: If wine is exposed to repeated vibration, it will disrupt the wine's biochemical development. Vibrations are often the reason why some of the best and finest wines fail to reach their optimal taste.

VENTILATION: Ventilation and the continuous circulation of air are fundamentally important to avoid the development of unpleasant odours.



WINE 32

DUAL TEMPERATURE
FREE STANDING

Classe Energetica
Energy efficiency class:



WINE 32/1

MONO TEMPERATURE
FREE STANDING



WINE 38

DUAL TEMPERATURE
BUILT-IN & FREE STANDING

Classe Energetica
Energy efficiency class:

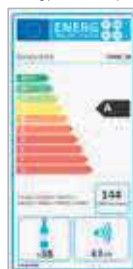

Vetri fumè con filtro anti-UV
Smoked glass door with UV-filter

LED di serie: superiore
Standard LED: top

Display digitale della temperatura
Digital temperature display

Centralina elettronica
Electronic temperature control

Griglie a filo in acciaio con inserto legno
Wire steel shelves with wood insert

Elegante maniglia in alluminio
Stylish aluminum handle

Colore standard
Standard color



COD. 13

	°C	Lt.	LxPxH mm	N° - mm. STANDARD	Watt	% U.R.	DEFROST	H ₂ O			0,75 Lt.	Kg.	
Wine 32	Comparto SUPERIORE: +5/+10 Comparto INFERIORE: +10/+18	106	493x625x830	4 mm. 418x426 2 mm. 413x288	96	60		AUT		R600a	n° 32 (14+18)	40	- LED Standard
Wine 32/1	+2/+10	106	493x625x830	2 mm. 418x426 1 mm. 413x288	96	60		AUT		R600a	n° 32 Ø 75 mm.	40	- LED Standard
Wine 38	+5/+18 +5/+18	140	600x610x820	10 mm. 216x430 2 mm. 204x300	110	60		AUT		R600a	n° 19+19 Ø 75 mm.	53	- LED Standard

Voltaggio di serie - Standard voltage: 230v/1/50Hz • Classe climatica - Climatic class: MAX = (30°C - % U.R. 55)



**VETRINE CLIMATIZZATE!
CONDITIONED WINE CABINETS!**

WINE 155 BLACK / WINE 185 BLACK / WINE 185:

- Guarnizione intercambiabile
- Centralina elettronica
- Display digitale della temperatura
- Termostato antigelo: tutte le unità hanno un termostato antigelo che escluderà il sistema in caso di raggiungimento dei 0°C.
- Filtro carbone
- Resistenza incorporata: sistema di riscaldamento, che permette per esempio,

inserendo l'unità in ambienti con temperatura di 10°C di ottenere comunque 18°C interni.

- Compressore a bassa vibrazione
- Vetri fumè con filtro anti-UV
- Elegante maniglia in alluminio
- Griglie in legno
- Porta reversibile

- Exchangeable gasket
- Electronic temperature control
- Digital temperature display
- Frost protection: all units have a frost protection thermostat which will cut off the system in case reaching zero degrees C.
- Charcoal filter
- Built-in heating element: heating system that allow to place the unit even at 10

degrees ambient temperature and reach internal temperature of 18 degrees.

- Low-vibration compressor
- Smoked glass door with UV-filter
- Stylish aluminum handle
- Wooden shelves
- Reversible door



OPTIONAL / OPTIONAL

Kit ripiani estraibili con guide / Kit ausziehbare Rosten mit Fuehrungspaar /
Kit extractibles shelves with guides / Kit étagères extraibles avec supports / Kit
estantes extraíbles con guías
Wine 155: MAX n° 8 Wine 185: MAX n° 10



DI SERIE/STANDARD

Griglia inclinata 45° / Inclined grate 45°
Grille inclinée à 45° / 45° geneigt Gitter
Rejilla inclinada 45°



ACCESSORIO/ACCESSORY

Termometro / Thermometer
Thermomètre / Thermometer / Termometro

WINE 155 BLACK

FREE STANDING

WINE 185 BLACK

FREE STANDING

WINE 185

FREE STANDING

DI SERIE / STANDARD:
 Griglia inclinata 45°
 Inclined grate 45°
 Grille inclinée à 45°
 45° geneigt Gitter
 Rejilla inclinada 45°
 mm. 520x230



Classe Energetica
 Energy efficiency class:



Colore standard
 Standard color



COD. 13



LED di serie: superiore
 Standard LED: top

Classe Energetica
 Energy efficiency class:



Colore standard
 Standard color



COD. 13



LED di serie: superiore
 Standard LED: top

Classe Energetica
 Energy efficiency class:



Colore standard
 Standard color



COD. 34



LED di serie: superiore
 Standard LED: top

	°C	Lt.	LxPxH mm	N° - mm. STANDARD	Watt	% U.R.	DEFROST	H ₂ O			0,75 Lt.	Kg.		
Wine 155 Black	+5/+22	298	600x670x1560	3 mm. 520x440 1 mm. 520x360 1 mm. 520x230	170	60		AUT		R600a	n° 146 Ø 75 mm.	75	Standard	LED Standard
Wine 185 Black	+5/+22	368	600x670x1860	4 mm. 520x440 1 mm. 520x360 1 mm. 520x230	170	60		AUT		R600a	n° 197 Ø 75 mm.	87	Standard	LED Standard
Wine 185	+5/+22	368	600x670x1860	4 mm. 520x440 1 mm. 520x360 1 mm. 520x230	170	60		AUT		R600a	n° 197 Ø 75 mm.	87	Standard	LED Standard

Voltaggio di serie - Standard voltage: 230v/1/50Hz • Classe climatica - Climatic class: MAX = (30°C - % U.R. 55)



FULL-GLASS LINE:

Linea completa di espositori "Full-Glass" affiancabili / Complete line of side-by-side "Full-Glass" displays

WINE FG



+5/+22

WINE FG BRUT



+2/+10

WINE FG RED



+15/+22

DRINK 360 FG



+2/+10

MEAT 360 DA FG



+1/+2

VPA 360 FG



+4/+10

VFS 360 FG



+6/+10

WINE FG



FILTRO A CARBONE: Dispositivo interno a carboni attivi che elimina i cattivi odori.
CHARCOAL FILTER: Internal filters with active carbons to avoid the bad smells.

Serie WINE FG: distintivo design con vetro nero

L'intramontabile vetro nero anteriore rende la serie Wine FG elegante e discreta anche quando in versione da incasso.

Il basamento inferiore è anch'esso rivestito da vetro nero, rendendo l'intero fronte della vetrina molto elegante. Sui modelli Wine 185 FG, l'apertura della porta è facilitata dalla maniglia integrata.

Le vetrine refrigerate per bibite Drink 360 FG sono costruite in modo da poter essere affiancate ai modelli Wine 185 FG, creando così una serie sbalorditiva per esporre qualsiasi bevanda. È disponibile un kit unione su misura, per bloccare le vetrine quando sono affiancate. Il kit unione fornisce la distanza necessaria per garantire l'accesso alla maniglia integrata, è inoltre presente una guarnizione di finitura tra le due vetrine.

WINE FG series: distinct, black-glass design

The timeless Black-Glass front makes the Wine FG series look elegant and discreet when integrated into a wall. Even the socket is covered by Black-Glass making the entire front very stylish. The door opening is made easy by pulling the integrated doorframe handle on Wine 185 FG.

Drink 360 FG beverage display cooler is built to match in a side-by-side solution with Wine 185 FG making a stunning set to display any drink. A tailor made joining kit is available to fix the cabinets when placed side-by-side. The joining kit provides the necessary distance between each cabinet to ensure access to the integrated doorframe handle and there is a gasket to join between the cabinets to finish nicely.

WINE 32 FG / WINE 45 FG:

- Griglie a filo in acciaio con inserto legno
- Centralina elettronica
- Display digitale della temperatura
- Filtro carbone
- Compressore a bassa vibrazione
- Vetri fumè con filtro anti-UV
- Porta in vetro
- Esclusiva vetrina vino, interamente in vetro
- Wire steel shelves with wood insert
- Electronic temperature control
- Digital temperature display
- Charcoal filter
- Low-vibration compressor
- Smoked glass door with UV-filter
- Glass door
- Exclusive full glass wine cabinet

WINE 185 FG:

- Guarnizione intercambiabile
- Centralina elettronica
- Display digitale della temperatura
- Termostato antigelo: tutte le unità hanno un termostato antigelo che escluderà il sistema in caso di raggiungimento dei 0°C.
- Filtro carbone
- Resistenza incorporata: sistema di riscaldamento, che permette per esempio, inserendo l'unità in ambienti con temperatura di 10°C di ottenere comunque 18°C interni.
- Compressore a bassa vibrazione
- Vetri fumè con filtro anti-UV
- Griglie in legno
- Porta reversibile
- Barre LED verticali sinistra/destra, integrate nel telaio della porta
- Serratura integrata
- Esclusiva vetrina vino, interamente in vetro
- Exchangeable gasket
- Electronic temperature control
- Digital temperature display
- Frost protection: all units have a frost protection thermostat which will cut off the system in case reaching zero degrees C.
- Charcoal filter
- Built-in heating element: heating system that allow to place the unit even at 10 degrees ambient temperature and reach internal temperature of 18 degrees.
- Low-vibration compressor
- Smoked glass door with UV-filter
- Wooden shelves
- Reversible door
- LED lines in door frame left/right
- Integrated lock
- Exclusive full glass wine cabinet



OPTIONAL / OPTIONAL

Kit ripiani estraibili con guide / Kit ausziehbare Rosten mit Führungspaar / Kit extractibles shelves with guides / Kit étagères extraibles avec supports / Kit estantes extraibles con guías
 Wine 185 FG: MAX n° 10



DI SERIE/STANDARD

Griglia inclinata 45° / Inclined grate 45° / Grille inclinée à 45° / 45° geneigt Gitter / Rejilla inclinada 45°

WINE 185 FG

FREE STANDING

DI SERIE/STANDARD:
 Griglia inclinata 45° / Inclined grate 45°
 Grille inclinée à 45° / 45° geneigt Gitter
 Rejilla inclinada 45°
 mm. 520x230



WINE 32 FG

FREE STANDING



WINE 45 FG

BUILT-IN & FREE STANDING



Colore standard
Standard color



COD. 13

Classe Energetica
Energy efficiency class:



LED di serie: superiore
Standard LED: top

Full-Glass per vino
Full-Glass for wine storage

Colore standard
Standard color



COD. 13

Classe Energetica
Energy efficiency class:



LED di serie: superiore
Standard LED: top

Full-Glass per vino
Full-Glass for wine storage

Colore standard
Standard color



COD. 13

Classe Energetica
Energy efficiency class:



LED di serie: superiore e laterali
Standard LED: top and sides

Full-Glass per vino
Full-Glass for wine storage

	°C	Lt.	LxPxH mm	N° - mm. STANDARD	Watt	% U.R.	DEFROST	H ₂ O			0,75 Lt.	Kg.		
Wine 32 FG	Comparto SUPERIORE: +5/+10 Comparto INFERIORE: +10/+18	106	493x587x840	4 mm. 413x423 2 mm. 413x290	100	-		AUT		R600a	n° 32 Ø 75 mm.	40	-	LED Standard
Wine 45 FG	Comparto SUPERIORE: +5/+10 Comparto INFERIORE: +10/+18	145	595x573x820/895	4 mm. 523x423 1 mm. 523x290	125	-		AUT		R600a	n° 45 Ø 75 mm.	51	Standard	LED Standard
Wine 185 FG	+5/+22	368	595x630x1860	4 mm. 520x440 1 mm. 520x360 1 mm. 520x230	170	-		AUT		R600a	n° 191 Ø 75 mm.	87	Standard	LED Standard

Voltaggio di serie - Standard voltage: 230v/1/50Hz • Classe climatica - Climatic class: MAX = (30°C - % U.R. 55)

WINE 185 FG RED



REFRIGERATORE "FULL-GLASS" PER VINO ROSSO
"FULL-GLASS" CABINET FOR RED WINE STORAGE

FREE STANDING



DI SERIE/STANDARD:
Griglia inclinata 45° / Inclined grate 45°
Grille inclinée à 45° / 45° geneigt Gitter
Rejilla inclinada 45°
mm. 520x230



Speciale per vini rossi
Special for red wines



Griglie in legno
Wooden shelves



LED di serie: superiore e laterali
Standard LED: top and sides

Classe Energetica
Energy efficiency class:



Colore standard
Standard color



COD. 13

	°C	Lt.	LxPxH mm	N° - mm. STANDARD	Watt	% U.R.	DEFROST	H ₂ O			0,75 Lt.	Kg.		
NEW Wine 185 FG RED	+15/+22	368	595x630x1860	4 mm. 520x440 1 mm. 520x360 1 mm. 520x230	170	-		AUT		R600a	n° 191 Ø 75 mm.	87	Standard	LED Standard

Voltaggio di serie - Standard voltage: 230v/1/50Hz • Classe climatica - Climatic class: MAX = (30°C - % U.R. 55)

WINE 185 FG BRUT



REFRIGERATORE "FULL-GLASS" PER VINO BIANCO
"FULL-GLASS" CABINET FOR WHITE WINE STORAGE

FREE STANDING



LED di serie:
superiore e laterali
Standard LED:
top and sides



Speciale per vini bianchi
Special for white wines



Griglie in legno
Wooden shelves

La nuova vetrina ventilata WINE 185 FG BRUT, è ideale per l'immagazzinamento delle bottiglie di vino bianco. Le sue linee eleganti permettono l'utilizzo in una vasta gamma di applicazioni del settore alberghiero e della ristorazione.

Efficiente illuminazione LED
L'illuminazione a LED crea una grande visibilità dei prodotti immagazzinati. In combinazione con il refrigerante R600a questa vetrina rappresenta una delle migliori proposte ad alta efficienza energetica presenti sul mercato.

Esclusivo design interamente in vetro.
Compressore a bassa vibrazione.

The new ventilated cooler, WINE 185 FG BRUT, is the perfect way to store white wine bottles. Its elegant design makes it suitable for a wide range of applications in hotel and restaurant sector.

Efficient LED lighting
The LED lighting allows a great visibility of products stored. Combined with refrigerant R600a, it currently represents one of the most energy-efficient units available on the market.

Exclusive full-glass design.
Low vibration compressor.

Classe Energetica
Energy efficiency class:



Colore standard
Standard color



COD. 13

	°C	Lt.	LxPxH mm	N° - mm. STANDARD	Watt	% U.R.	DEFROST	H ₂ O		0,75 Lt.		Kg.	
Wine 185 FG BRUT	+2/+10	368	595x630x1860	5 mm. 520x440 1 mm. 520x360	250	60		AUT		n° 191 Ø 75 mm.	R600a	87	LED Standard

Voltaggio di serie - Standard voltage: 230v/1/50Hz • Classe climatica - Climatic class: MAX = (30°C - % U.R. 55)

VKG BLACK



VKG 581 BLACK

**BUILT-IN &
FREE STANDING**

Classe Energetica
Energy efficiency class:



LED di serie: superiore
Standard LED: top

Serratura di serie / Lock standard

Termometro meccanico esterno
Mechanical external thermometer

Griglie in legno / Wooden shelves

Vetri fumè con filtro anti-UV
Smoked glass door with UV-filter



Termometro optional
Optional thermometer
Thermomètre optional
Optional Thermometer
Termometro optional



OPTIONAL:
Kit ventilazione interna
Kit internal ventilation
Kit ventilation interne
Inneres Umluftungskit
Kit ventilacion interna

VKG 511 BLACK

FREE STANDING



Classe Energetica
Energy efficiency class:



Colore standard
Standard color

COD. 13

	°C	Lt.	LxPxH mm	N° - mm. STANDARD	Watt	% U.R.	DEFROST	H ₂ O			0,75 Lt.	Kg.		
VKG 511 Black	+6/+16	300	595x595x1550	3 mm. 510x395 1 mm. 510x295	125	60		AUT		R600a	n° 89 Ø 75 mm.	66	Standard	LED Standard
VKG 581 Black	+6/+16	355	595x595x1850	5 mm. 510x395	125	60		AUT		R600a	n° 106 Ø 75 mm.	71	Standard	LED Standard

Voltaggio di serie - Standard voltage: 230v/1/50Hz • Classe climatica - Climatic class: MAX = (30°C - % U.R. 55)

CVKS BLACK



CVKS 680 BLACK

Classe Energetica
Energy efficiency class:



CVKS 681 BLACK



Colore standard
Standard color



COD. 13

FREE STANDING

	°C	Lt.	LxPxH mm	N° - mm. DI SERIE	Watt	% U.R.	DEFROST	H ₂ O			0,75 Lt.	Kg.		
CVKS 680 Black	+6/+16	338	600x632x1860	5 mm. 510x395	125	60		AUT		R600a	n° 106 Ø 75 mm.	64	Di serie	Di serie
CVKS 681 Black	+6/+16	341	600x632x1860	5 mm. 510x395	125	60		AUT		R600a	n° 106 Ø 75 mm.	62	Di serie	Di serie

Voltaggio di serie - Standard voltage: 230v/1/50Hz • Classe climatica - Climatic class: MAX = (30°C - % U.R. 55)

WINE

WINE 32 **DUAL TEMPERATURE**
FREE STANDING

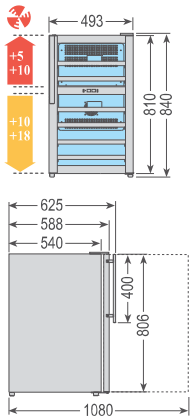

NB: Condensazione statica a parete/fianchi
Wall (sides) static condensation



WINE 32/1 **MONO TEMPERATURE**
FREE STANDING

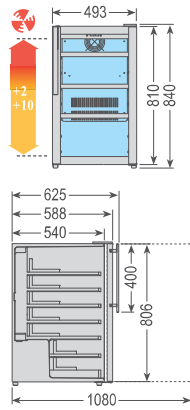

NB: Condensazione statica a parete/fianchi
Wall (sides) static condensation



WINE 38 **DUAL TEMPERATURE**
BUILT-IN & FREE STANDING

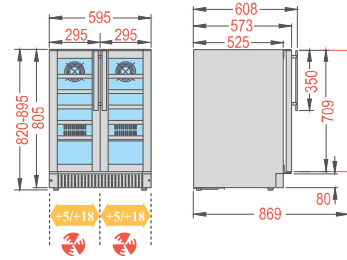

FREE-STANDING & BUILT-IN VERSION

La presa d'aria frontale permette di utilizzare questo modello libero o da incasso

The front air intake allows to use this model as free standing or built-in version

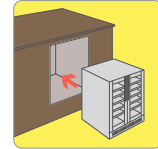

WINE 155 BLACK **FREE STANDING**

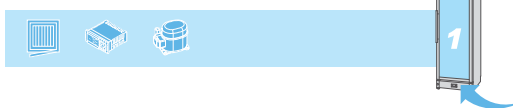
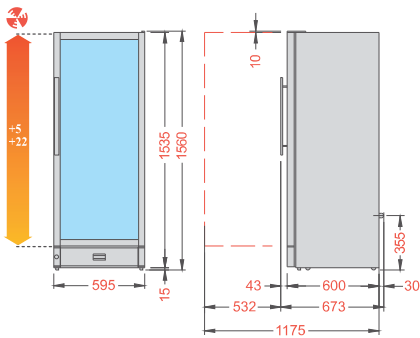

WINE 185 / WINE 185 BLACK **FREE STANDING**

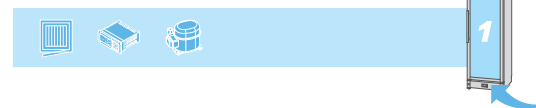
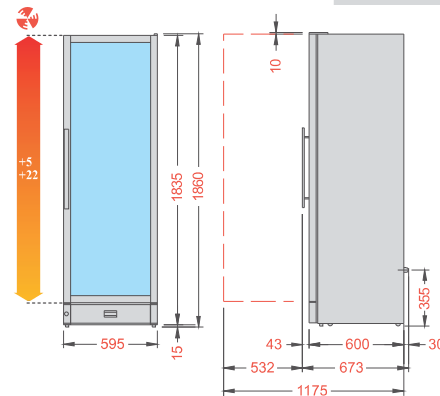

WINE FG

WINE 32 FG **DUAL TEMPERATURE**
ONLY FREE STANDING

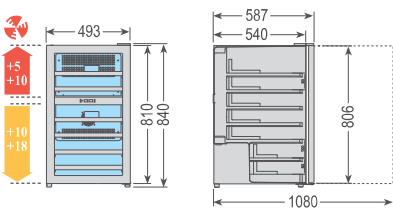

NB: Condensazione statica a parete/fianchi
Wall (sides) static condensation



WINE 45 FG **DUAL TEMPERATURE**
BUILT-IN & FREE STANDING

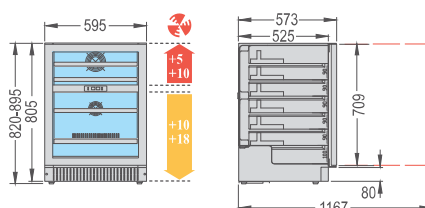

FREE-STANDING & BUILT-IN VERSION

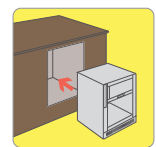

La presa d'aria frontale permette di utilizzare questo modello libero o da incasso

The front air intake allows to use this model as free standing or built-in version

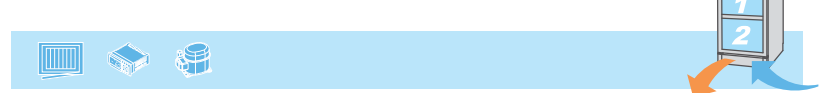

WINE 185 FG FREE STANDING

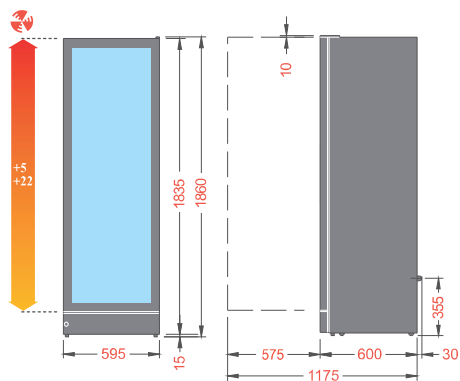

WINE 185 FG BRUT FREE STANDING

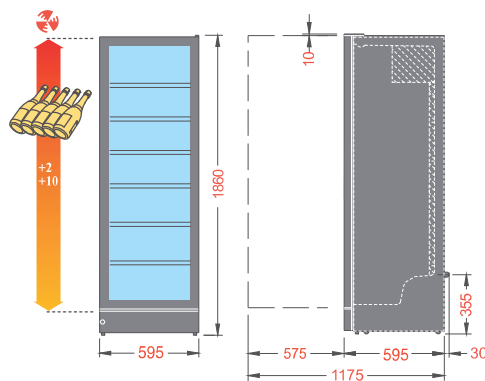

WINE 185 FG RED FREE STANDING

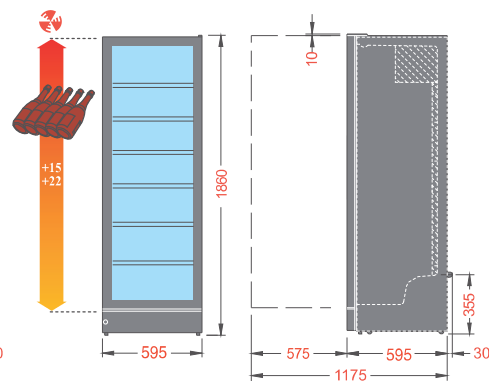

VKG BLACK / CVKS BLACK

VKG 511 BLACK FREE STANDING

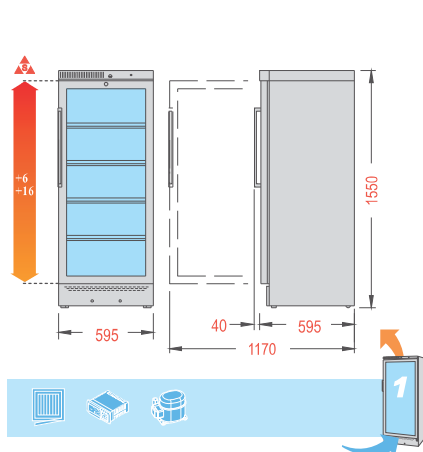

VKG 581 BLACK BUILT-IN & FREE STANDING

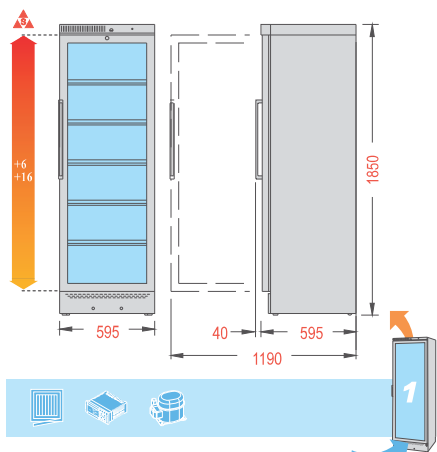

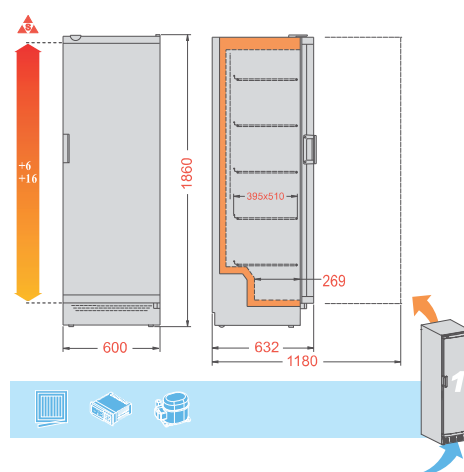

CVKS 681 BLACK FREE STANDING



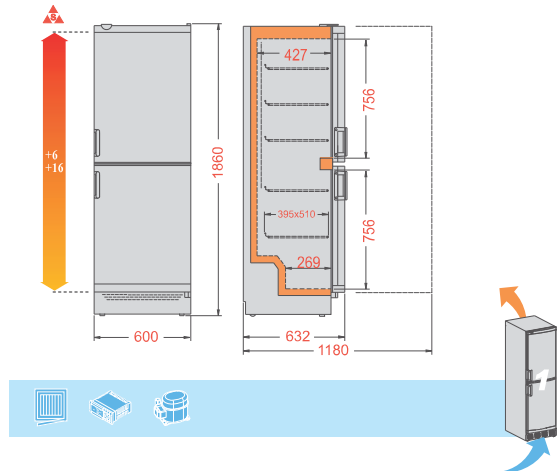

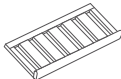
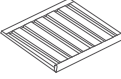
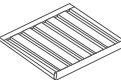
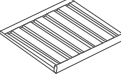

CVKS 680 BLACK FREE STANDING

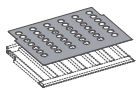
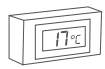

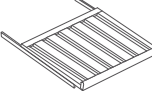
MOD.	LxPxH mm	Kg	container n°(20')	container n°(40')	colore colour color
WINE 32	550x645x940	44	60	126	COD.13
WINE 32/1	545x650x940	44	60	132	COD.13
WINE 38	655x665x870	57	48	108	COD.13
WINE 155 BLACK	640x680x1750	76	27	54	COD.13
WINE 185 BLACK	640x680x2040	88	27	54	COD.13
WINE 185	640x680x1940	88	27	54	COD.34
WINE 32 FG	550x650x1000	50	54	108	COD.13
WINE 45 FG	640x680x1000	61	54	108	COD.13
WINE 185 FG	640x671x1930	90	27	72	COD.13
WINE 185 FG RED	640x671x1930	90	27	72	COD.13
WINE 185 FG BRUT	650x680x2060	92	27	72	COD.13
VKG 511 BLACK	640x670x1750	71	27	54	COD.13
VKG 581 BLACK	640x670x1940	76	27	54	COD.13
CVKS 680 BLACK	635x675x1940	66	27	54	COD.13
CVKS 681 BLACK	635x675x1940	64	27	54	COD.13

Accessori - Accessories - Accessoires - Zuberhör - Accesorios		MOD.	 Codice
	Griglia a 45° / Grille inclined to 45° / Grille inclinée à 45° / Gitter um 45° / Rejilla inclinada a 45°	WINE 155 BLACK WINE 185 BLACK WINE 185 WINE 185 FG	A120802
	Griglia in legno inferiore / Lower wooden grille / Grille inférieur en bois / Unteren Gitter Holz / Rejilla de madera inferior	WINE 155 BLACK WINE 185 BLACK WINE 185 WINE 185 FG WINE 185 FG BRUT	A120805
	Griglia in legno superiore / Upper wooden grille / Grille supérieure en bois / Oberen Gitter Holz / Rejilla de madera superior	WINE 155 BLACK WINE 185 BLACK WINE 185 WINE 185 FG WINE 185 FG BRUT	A120806
	Griglia ripiano / Grille shelf / Grille clayette / Gitter Schrankbrett / Rejilla estantes	VKG 511 BLACK VKG 581 BLACK CVKS 680 BLACK CVKS 681 BLACK	8980804
	Kit unione / Union kit / Kit union / Verbindung kit / Kit uniones	WINE 155 BLACK WINE 185 BLACK WINE 185 WINE 185 FG	Q4802/2
	Piano forato in PST per posizionamento bottiglie in verticale / Perforated PST shelf to put bottles in vertical position / Étagère perforé pour positionner les bouteilles en position verticale / Estante perforado en PST para posicionar botellas en vertical. / Gelochtes kompaktes Polystyrol boden für die auflage von vertikalen flaschen	WINE 155 BLACK WINE 185 BLACK WINE 185 WINE 185 FG VKG 511 BLACK VKG 581 BLACK CVKS 680 BLACK CVKS 681 BLACK	A120807 8980805
	Termometro digitale per ripiani in legno / Digital thermometer for wooden shelves / Thermomètre digital pour plateaux en bois / Digitales Thermometer fuer Holzablagen / Termometro digital por estantes de madera	WINE 155 BLACK WINE 185 BLACK WINE 185 WINE 185 FG VKG 511 BLACK VKG 581 BLACK CVKS 680 BLACK CVKS 681 BLACK	A0609

Optional - Optionnel - Extra - Extras		MOD.
	115V/60Hz Non disponibile per questi modelli / 115V/60Hz Not available for these models / 115V/60Hz Non disponible pour ces modèles / 115V/60Hz Nicht verfügbar für dieses Modelle / 115V/60Hz No disponible para estos modelos	VKG 581 BLACK CVKS 680 BLACK CVKS 681 BLACK
	Kit ripiano estraibile con guide / Kit extractible shelve with guides / Kit étagère extraible avec supports / Kit ausziehbare Rosten mit Führungspaar / Kit estante extraible con guías	WINE 155 BLACK WINE 185 BLACK WINE 185 WINE 185 FG
	Kit ventilatore / Fan assisted kit / Kit ventilateur / Kit Luefter / Kit ventilador	VKG 511 BLACK VKG 581 BLACK CVKS 680 BLACK CVKS 681 BLACK
	Vetri per altitudine / Glasses suitable for altitude / Glaces pour altitude / Für die höhe passende Gläser / Vidrios para altura	WINE 38 WINE 155 BLACK WINE 185 BLACK WINE 185 WINE 32 FG WINE 45 FG WINE 185 FG WINE 185 FG BRUT VKG 581 BLACK

Optional - Optionnel - Extra - Extras		MOD.
	Supplemento per inversione porta / Supplement for door inversion / Supplément pour inversion de porte / Zuschlag für Türumkehrung / Suplemento para inversión de puertas	Per informazioni vi preghiamo di contattare il nostro ufficio commerciale / For information, please contact our export department / Pour informations, veuillez contacter notre service commercial / Für Informationen kontaktieren Sie bitte unsere Verkaufsabteilung / Si necesita información adicional, no dude en ponerse en contacto con nuestro departamento de venta
	Supplemento per presa elettrica diversa dalla standard / Supplement for electric socket different than the standard / Supplément pour prise électrique différent de la norme / Aufpreis für Steckdose abweichend vom Standard / Suplemento para toma de corriente diferente al estándar	

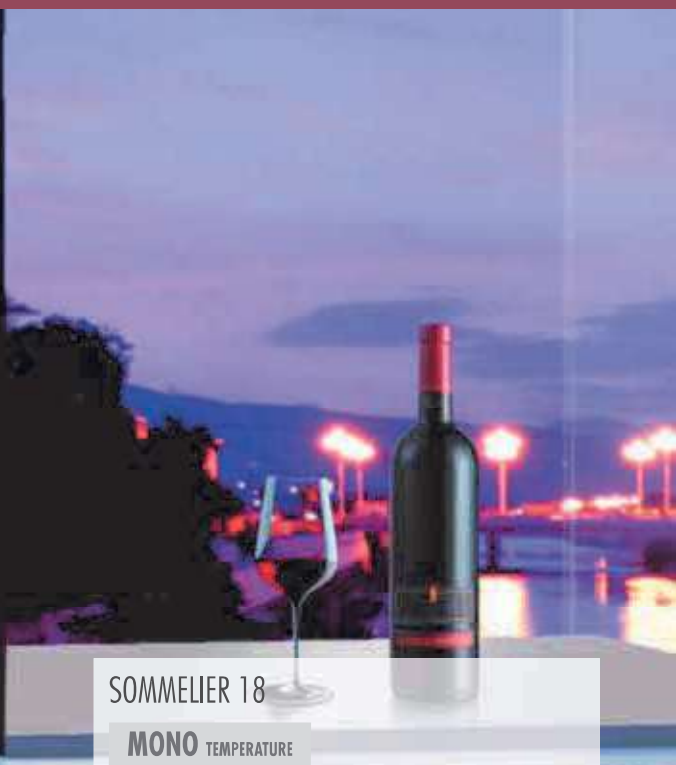

SOMMELIER 18

MONO TEMPERATURE
BUILT-IN ONLY



Classe Energetica
Energy efficiency class:



Consumo: solo 1,63 Kw/24h
Power consumption: only 1.63 kW/24h

Questo modello di cantinetta per vino di piccole dimensioni con funzionamento a compressore è stato pensato esclusivamente da incasso, ideale anche per uso domestico. Il suo elegante design nero lucido si adatta ad ogni tipo di arredamento.

This small wine showcase model with compressor has been created exclusively to be built in , perfect also for domestic use. Its elegant bright black design is suitable for each kind of furnishing.



Vetri fumè con filtro anti-UV
Smoked glass door with UV-filter

Pulsanti in alluminio, robusti e durevoli
Aluminum button, sturdy and durable



Luce LED blu di serie / Blue LEDs light standard

Display digitale della temperatura
Digital temperature display

Centralina elettronica / Electronic temperature control



Griglie telescopiche in legno di faggio
Beech wooden sliding shelves



Elegante maniglia in acciaio satinato
Elegant brushed stainless steel handle

SOMMELIER



SOMMELIER 43/1

MONO TEMPERATURE

BUILT-IN & FREE STANDING



SOMMELIER 43

DUAL TEMPERATURE

BUILT-IN & FREE STANDING



SOMMELIER 63

DUAL TEMPERATURE

FREE STANDING



Classe Energetica
Energy efficiency class:



i PORTA NON REVERSIBILE
NOT REVERSIBLE DOOR

Classe Energetica
Energy efficiency class:

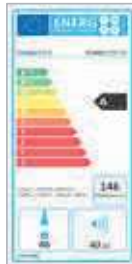

i PORTA NON REVERSIBILE
NOT REVERSIBLE DOOR

Vetrina vino 2 scomparti con temperature regolabili indipendentemente
Dual zone wine cabinet with temperatures independently adjustable

Classe Energetica
Energy efficiency class:



Vetrina vino 2 scomparti con temperature regolabili indipendentemente
Dual zone wine cabinet with temperatures independently adjustable

Serratura con chiave a brugola di serie
Lock with Allen key standard

Colore standard
Standard color



COD. 13

	°C	Lt.	LxPxH mm	N° - mm. STANDARD	Watt	% U.R.	No frost	H ₂ O	AUT	R600a	0,75 Lt.	Kg.		LED
Sommelier 18	+5/+20	50	590x596x455	3 mm. 444x337	68	-	No frost	AUT		R600a	n° 18 Ø 75 mm.	21	-	Standard
Sommelier 43/1	+5/+20	142	595x580x814	4 mm. 498x442 1 mm. 498x330	100	-		AUT		R600a	n° 51 Ø 75 mm.	40	Standard	LED
Sommelier 43	COMPARTO SUPERIORE: +5/+12 COMPARTO INFERIORE: +12/+22	130	595x580x814	4 mm. 498x442 1 mm. 498x330	100	-		AUT		R600a	n° 40 Ø 75 mm.	42	Standard	LED
Sommelier 63	COMPARTO SUPERIORE: +5/+12 COMPARTO INFERIORE: +12/+22	190	595x580x1020	6 mm. 498x442 1 mm. 498x330	120	-		AUT		R600a	n° 66 Ø 75 mm.	53	Standard	LED

Voltaggio di serie - Standard voltage: 230v/1/50Hz • Classe climatica - Climatic class: MAX = (30°C - % U.R. 55)

SOMMELIER 301

MONO TEMPERATURE

FREE STANDING



Classe Energetica
Energy efficiency class:



SOMMELIER 302

DUAL TEMPERATURE

FREE STANDING



Classe Energetica
Energy efficiency class:



i Vetrina vino 2 scomparti con temperature regolabili indipendentemente
Dual zone wine cabinet with temperatures independently adjustable



DI SERIE / STANDARD:
Griglie telescopiche in legno
Wooden sliding shelves
Sommelier 301: n° 7
Sommelier 302: n° 7

OPTIONAL / OPTIONAL:
Sommelier 301: + MAX n° 8
Sommelier 302: + MAX n° 7



OPTIONAL / OPTIONAL:
Griglia grande con supporto per bottiglie inclinate / Big shelf with inclined bottles support / Gros grille avec support pour bouteilles inclinées / Große Gitter mit Halterung für schräge Weinflaschen / Rejilla grande con soportes para botellas inclinadas.
Sommelier 301: MAX n° 6
Sommelier 302: MAX n° 6

Bottiglie/Bottles, H. MAX: 30 cm



Vetri fumè con filtro anti-UV
Smoked glass door with UV-filter

Pulsanti in alluminio, robusti e durevoli
Aluminum button, sturdy and durable



Luce LED blu di serie / Blue LEDs light standard

Display digitale della temperatura
Digital temperature display

Centralina elettronica / Electronic temperature control



Serratura con chiave a brugola di serie
Lock with Allen key standard

Colore standard
Standard color

COD. 13

SOMMELIER 481

MONO TEMPERATURE

FREE STANDING



Classe Energetica
Energy efficiency class:



SOMMELIER 482

DUAL TEMPERATURE

FREE STANDING



Classe Energetica
Energy efficiency class:

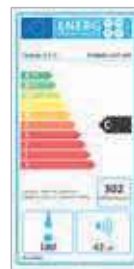

Vetrina vino 2 scomparti con temperatura regolabili indipendentemente
Dual zone wine cabinet with temperatures independently adjustable



DI SERIE / STANDARD:
Griglie telescopiche in legno
Wooden sliding shelves
Sommelier 481: n° 8
Sommelier 482: n° 8

OPTIONAL / OPTIONAL:
Sommelier 481: + MAX n° 9
Sommelier 482: + MAX n° 8



OPTIONAL / OPTIONAL:
Griglia grande con supporto per bottiglie inclinate
Big shelf with inclined bottles support / Gros grille avec support pour bouteilles inclinées / Große Gitter mit Halterung für schräge weinflaschen / Rejilla grande con soportes para botellas inclinadas.
Sommelier 481: MAX n° 7
Sommelier 482: MAX n° 7

Bottiglie/Bottles, H. MAX: 30 cm

	°C	Lt.	LxPxH mm	N° - mm. STANDARD	Watt	% U.R.				0,75 Lt.	Kg.		
Sommelier 301	+5/+20	270	595x580x1590	6 mm. 503x437 1 mm. 503x325	170	-		AUT		R600a n° 129 Ø 75 mm.	76	Standard	LED Standard
Sommelier 302	COMPARTO SUPERIORE: +5/+12 COMPARTO INFERIORE: +12/+22	270	595x580x1590	6 mm. 503x437 1 mm. 503x325	170	-		AUT		R600a n° 120 Ø 75 mm.	76	Standard	LED Standard
Sommelier 481	+5/+20	480	595x680x1840	7 mm. 503x530 1 mm. 503x420	170	-		AUT		R600a n° 192 Ø 75 mm.	90	Standard	LED Standard
Sommelier 482	Compartmento SUPERIORE: +5/+12 Compartmento INFERIORE: +12/+22	480	595x680x1840	7 mm. 503x530 1 mm. 503x420	170	-		AUT		R600a n° 181 Ø 75 mm.	90	Standard	LED Standard

Voltaggio di serie - Standard voltage: 230v/1/50Hz • Classe climatica - Climatic class: MAX = (30°C - % U.R. 55)

SOMMELIER PLUS



SOMMELIER 24 PLUS

MONO TEMPERATURE

BUILT-IN ONLY

Struttura della porta in acciaio inox, vetro a doppio strato trasparente con protezione UV
 Stainless steel door frame, transparent double layers glass door with UV protection



SOMMELIER 40 PLUS

DUAL TEMPERATURE

FREE STANDING



SOMMELIER 40/1 PLUS

MONO TEMPERATURE

FREE STANDING



Classe Energetica
 Energy efficiency class:

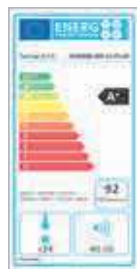

i **OPTIONAL / OPTIONAL:**
 Porta reversibile
 The door can be reversed

Classe Energetica
 Energy efficiency class:



i **OPTIONAL / OPTIONAL:**
 Porta reversibile
 The door can be reversed

Classe Energetica
 Energy efficiency class:



i **OPTIONAL / OPTIONAL:**
 Porta reversibile
 The door can be reversed

Colore standard
 Standard color



COD. 13

	°C	Lt.	LxPxH mm	N° - mm. STANDARD	Watt	% U.R.	DEFROST	H ₂ O			0,75 Lt.	Kg.	
Sommelier 24 Plus	+5/+20	51	592x559x455	3 mm. 465x305	127	-		AUT		R600a	n° 24 Ø 75 mm.	24,5	-
Sommelier 40 Plus	COMPARTO SUPERIORE: +12/+20 COMPARTO INFERIORE: +5/+12	111	485x600x820	4 mm. 394x455	119	-	No frost	AUT		R600a	n° 38 Ø 75 mm.	39	Standard
Sommelier 40/1 Plus	+5/+20	120	485x600x820	5 mm. 394x455	119	-	No frost	AUT		R600a	n° 44 Ø 75 mm.	37	Standard

Voltaggio di serie - Standard voltage: 230v/1/50Hz • Classe climatica - Climatic class: MAX = (30°C - % U.R. 55)

SOMMELIER 51 PLUS

MONO TEMPERATURE

BUILT-IN ONLY



SOMMELIER 51 PLUS FG

Versione FULL-GLASS
FULL GLASS version



SOMMELIER 52 PLUS

DUAL TEMPERATURE

BUILT-IN ONLY



SOMMELIER 52 PLUS FG

Versione FULL-GLASS
FULL GLASS version



Classe Energetica
Energy efficiency class:



i **OPTIONAL / OPTIONAL:**
Porta reversibile
The door can be reversed

Classe Energetica
Energy efficiency class:



i **OPTIONAL / OPTIONAL:**
Porta reversibile
The door can be reversed

Colore standard
Standard color



COD. 13

	°C	Lt.	LxPxH mm	N° - mm. STANDARD	Watt	% U.R.	REFROST	H ₂ O		0,75 Lt.	Kg.		
NEW Sommelier 51 Plus	+5/+20	108	592x555x885	6 mm. 452x305	110	-		AUT		R600a n° 48 Ø 75 mm.	43	-	LED Standard
NEW Sommelier 52 Plus	COMPARTO SUPERIORE: +5/+20 COMPARTO INFERIORE: +5/+20	100	592x555x885	5 mm. 452x305	110	-		AUT		R600a n° 42 Ø 75 mm.	45	-	LED Standard
NEW Sommelier 51 Plus FG	+5/+20	108	592x555x885	6 mm. 452x305	110	-		AUT		R600a n° 48 Ø 75 mm.	43	-	LED Standard
NEW Sommelier 52 Plus FG	COMPARTO SUPERIORE: +5/+20 COMPARTO INFERIORE: +5/+20	100	592x555x885	5 mm. 452x305	110	-		AUT		R600a n° 42 Ø 75 mm.	45	-	LED Standard

Voltaggio di serie - Standard voltage: 230v/1/50Hz • Classe climatica - Climatic class: MAX = (30°C - % U.R. 55)

SOMMELIER 80 PLUS

DUAL TEMPERATURE

BUILT-IN



SOMMELIER 80/1 PLUS

MONO TEMPERATURE

BUILT-IN



SOMMELIER 351 PLUS

MONO TEMPERATURE

BUILT-IN



Classe Energetica
Energy efficiency class:

i OPTIONAL / OPTIONAL:
Porta reversibile
The door can be reversed



Classe Energetica
Energy efficiency class:

i OPTIONAL / OPTIONAL:
Porta reversibile
The door can be reversed



Classe Energetica
Energy efficiency class:

i OPTIONAL / OPTIONAL:
Porta reversibile
The door can be reversed



FILTRO A CARBONE: Dispositivo interno a carboni attivi che elimina i cattivi odori /
CHARCOAL FILTER: Internal filters with active carbons to avoid the bad smells
(NO SOMMELIER 24 PLUS)



Pannello di controllo touchpad con illuminazione di sfondo /
Touchpad control panel with background illumination



Struttura della porta in acciaio inox / Stainless steel door frame
Maniglia tubolare lunga / Long tubular handle
Vetro a triplo strato con protezione UV / Triple layers glass door with UV protection (NO SOMMELIER 24 PLUS)



Griglie estraibili di serie
Sliding roller as standard



Elegante griglia di aerazione in acciaio inox
Elegant stainless steel ventilation plinth



Luce LED bianca
White LED light

ACCESSORI/ACCESSORIES:



Portabicchieri / Glass rack



Griglia espositiva / Display shelf
Bottiglie/Bottles, H. MAX: 30 cm

SOMMELIER 352 PLUS

DUAL TEMPERATURE
BUILT-IN



Classe Energetica
Energy efficiency class:

i OPTIONAL / OPTIONAL:
Porta reversibile
The door can be reversed

Colore standard
Standard color



COD. 13

SOMMELIER 401 PLUS

MONO TEMPERATURE BUILT-IN



Classe Energetica
Energy efficiency class:

i OPTIONAL / OPTIONAL:
Porta reversibile
The door can be reversed

SOMMELIER 402 PLUS

DUAL TEMPERATURE BUILT-IN



Classe Energetica
Energy efficiency class:

i OPTIONAL / OPTIONAL:
Porta reversibile
The door can be reversed

	°C	Lt.	LxPxH mm	N° - mm. STANDARD	Watt	% U.R.	No frost	H ₂ O		R600a	n° 0,75 Lt.	Kg.		LED Standard
Sommelier 80 Plus	COMPARTO SUPERIORE: +12/+20 COMPARTO INFERIORE: +5/+12	190	595x710x1000	5 mm. 481x545	119	-	No frost	AUT		R600a	n° 74 Ø 75 mm.	58	Standard	LED Standard
Sommelier 80/1 Plus	+5/+20	206	595x710x1000	7 mm. 481x545	119	-	No frost	AUT		R600a	n° 83 Ø 75 mm.	55	Standard	LED Standard
Sommelier 351 Plus	+5/+20	280	595x710x1270	10 mm. 481x545	178	-	No frost	AUT		R600a	n° 112 Ø 75 mm.	71	Standard	LED Standard
Sommelier 352 Plus	COMPARTO SUPERIORE: +12/+20 COMPARTO INFERIORE: +5/+12	163	595x710x1270	8 mm. 481x545	178	-	No frost	AUT		R600a	n° 104 Ø 75 mm.	74	Standard	LED Standard
Sommelier 401 Plus	+5/+20	403	595x710x1720	15 mm. 481x545	178	-	No frost	AUT		R600a	n° 163 Ø 75 mm.	92	Standard	LED Standard
Sommelier 402 Plus	COMPARTO SUPERIORE: +12/+20 COMPARTO INFERIORE: +5/+12	387	595x710x1720	13 mm. 481x545	178	-	No frost	AUT		R600a	n° 154 Ø 75 mm.	94	Standard	LED Standard

Voltaggio di serie - Standard voltage: 230v/1/50Hz • Classe climatica - Climatic class: MAX = (30°C - % U.R. 55)

SOMMELIER 601 PLUS

MONO TEMPERATURE

FREE STANDING



SOMMELIER 602 PLUS

DUAL TEMPERATURE

FREE STANDING



SOMMELIER 603 PLUS

TRIPLE TEMPERATURE

FREE STANDING



Classe Energetica
Energy efficiency class:



i PORTA NON REVERSIBILE
NOT REVERSIBLE DOOR



Classe Energetica
Energy efficiency class:



i PORTA NON REVERSIBILE
NOT REVERSIBLE DOOR



Classe Energetica
Energy efficiency class:



i PORTA NON REVERSIBILE
NOT REVERSIBLE DOOR

STANDARD / DI SERIE:

- Porta in acciaio inox AISI 304 senza saldatura con vetro basso emissivo a 2 strati / Seamless AISI 304 stainless steel door frame with 2 layer LOW-E glass
- Ripiani in legno con guide telescopiche e profili in acciaio inossidabile / Wooden shelves with telescopic rails and stainless steel trims
- Pannello comandi con display LCD sulla maniglia porta / Control panel with LCD display on the door handle
- LED laterali a luce calda / LED sidelights with warm light
- Filtro a carbone / Charcoal filter

ACCESSORI/ACCESSORIES:



Portabicchieri / Glass rack

Griglia espositiva / Display shelf
Bottiglie/Bottles, H. MAX: 30 cm

Colore standard
Standard color

COD. 13

	°C	Lt.	LxPxH mm	N° - mm. STANDARD	Watt	% U.R.	DEFROST	H ₂ O		0,75 Lt.	Kg.		
NEW Sommelier 601 Plus	+5/+20	642	750x710x2000	18 mm. 540x637	175	-		AUT		n° 303 Ø 75 mm.	143	Standard	LED Standard
NEW Sommelier 602 Plus	COMPARTO SUPERIORE: +10/+20 COMPARTO INFERIORE: +5/+12	630	750x710x2000	17 mm. 540x637	175	-		AUT		n° 270 Ø 75 mm.	146	Standard	LED Standard
NEW Sommelier 603 Plus	COMPARTO SUPERIORE: +10/+20 COMPARTO CENTRALE: +10/+20 COMPARTO INFERIORE: +5/+12	617	750x710x2000	16 mm. 540x637	175	-		AUT		n° 255 Ø 75 mm.	148	Standard	LED Standard

Voltaggio di serie - Standard voltage: 230v/1/50Hz • Classe climatica - Climatic class: MAX = (10-32°C - % U.R. 50)

SOMMELIER

SOMMELIER 18

MONO TEMPERATURE

ONLY BUILT-IN

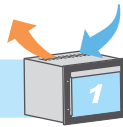
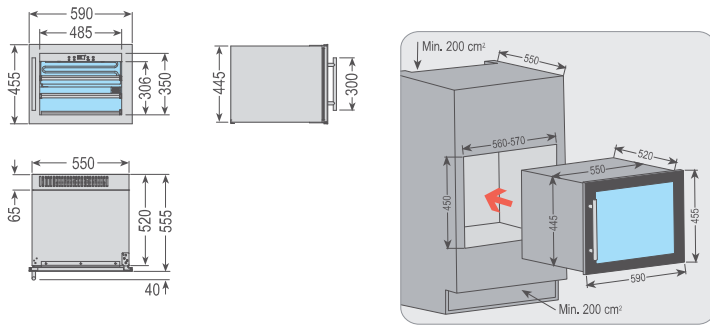

SOMMELIER 43

DUAL TEMPERATURE

BUILT-IN & FREE STANDING

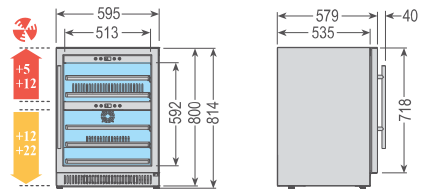

NB: Settare la temperatura del comparto superiore, sempre più bassa rispetto al comparto inferiore.
Setting temperature of upper zone, always lower than down zone.

La presa d'aria frontale permette di utilizzare questo modello libero o da incasso

The front air intake allows to use this model as free standing or built-in version

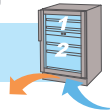
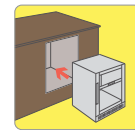

SOMMELIER 43/1

MONO TEMPERATURE

BUILT-IN & FREE STANDING

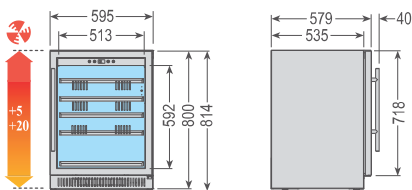

La presa d'aria frontale permette di utilizzare questo modello libero o da incasso

The front air intake allows to use this model as free standing or built-in version

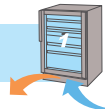
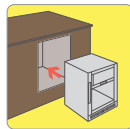

SOMMELIER 63

DUAL TEMPERATURE

FREE STANDING

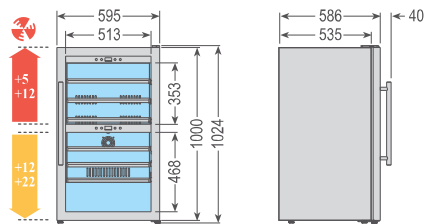

NB: Settare la temperatura del comparto superiore, sempre più bassa rispetto al comparto inferiore.
Setting temperature of upper zone, always lower than down zone.

OPTIONAL: Porta invertita da ordinare al momento dell'acquisto
Reversed door to order when buying

NB: Condensazione statica a parete/fianchi
Wall (sides) static condensation

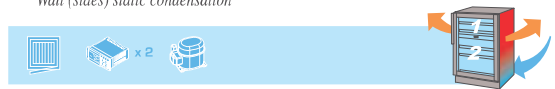

SOMMELIER 301

MONO TEMPERATURE

FREE STANDING

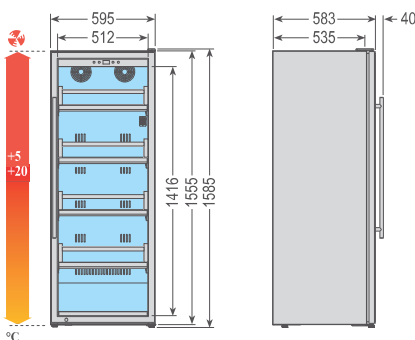

OPTIONAL: Porta invertita da ordinare al momento dell'acquisto
Reversed door to order when buying

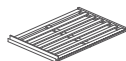

OPTIONAL: Griglie telescopiche in legno
Wooden sliding shelves
MAX n°8



OPTIONAL: Griglia grande con supporto per bottiglie inclinate
Big shelf with inclined bottles support
MAX n°6

NB: Condensazione statica a parete/fianchi
Wall (sides) static condensation



SOMMELIER 302

DUAL TEMPERATURE

FREE STANDING

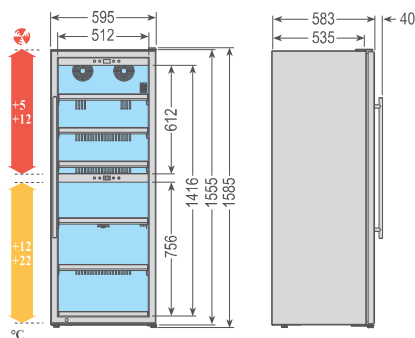

NB: Settare la temperatura del comparto superiore, sempre più bassa rispetto al comparto inferiore.
Setting temperature of upper zone, always lower than down zone.

OPTIONAL:
 Porta invertita da ordinare al momento dell'acquisto
Reversed door to order when buying

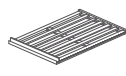

OPTIONAL:
 Griglie telescopiche in legno
Wooden sliding shelves
 MAX n°7



OPTIONAL:
 Griglia grande con supporto per bottiglie inclinate
Big shelf with inclined bottles support
 MAX n°6

NB: Condensazione statica a parete/fianchi
Wall (sides) static condensation

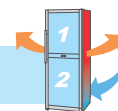

SOMMELIER 481

MONO TEMPERATURE

FREE STANDING

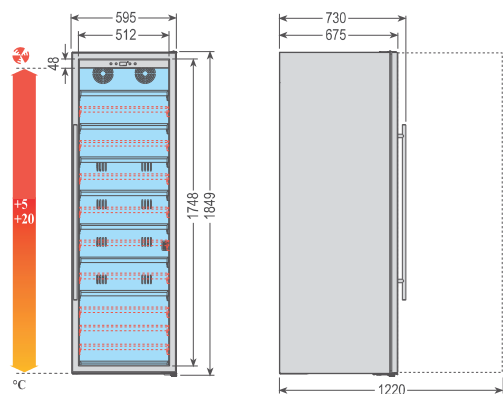

OPTIONAL:
 Porta invertita da ordinare al momento dell'acquisto
Reversed door to order when buying



OPTIONAL:
 Griglie telescopiche in legno
Wooden sliding shelves
 MAX n°9



OPTIONAL:
 Griglia grande con supporto per bottiglie inclinate
Big shelf with inclined bottles support
 MAX n°7

NB: Condensazione statica a parete/fianchi
Wall (sides) static condensation

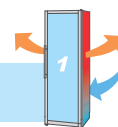

SOMMELIER 482

DUAL TEMPERATURE

FREE STANDING

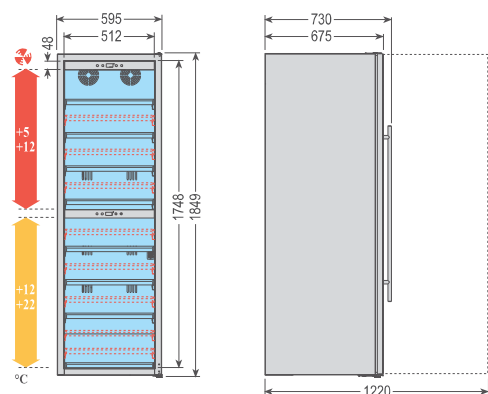

NB: Settare la temperatura del comparto superiore, sempre più bassa rispetto al comparto inferiore.
Setting temperature of upper zone, always lower than down zone.

OPTIONAL:
 Porta invertita da ordinare al momento dell'acquisto
Reversed door to order when buying



OPTIONAL:
 Griglie telescopiche in legno
Wooden sliding shelves
 MAX n°8



OPTIONAL:
 Griglia grande con supporto per bottiglie inclinate
Big shelf with inclined bottles support
 MAX n°7

NB: Condensazione statica a parete/fianchi
Wall (sides) static condensation

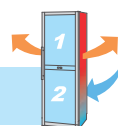

SOMMELIER PLUS

SOMMELIER 24 PLUS

MONO TEMPERATURE

ONLY BUILT-IN

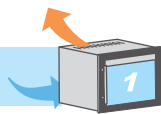
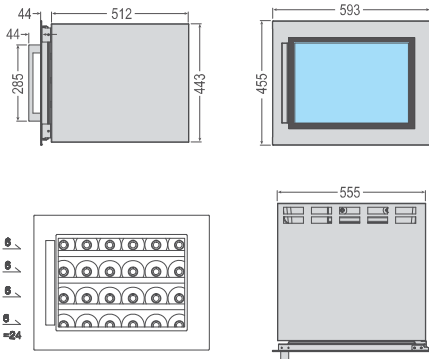

SOMMELIER 40 PLUS

DUAL TEMPERATURE

FREE STANDING

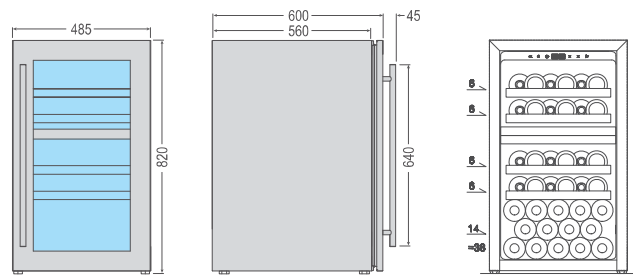

NB: Condensazione statica a parete/fianchi
Wall (sides) static condensation

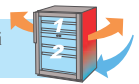

SOMMELIER 40/1 PLUS

MONO TEMPERATURE

FREE STANDING

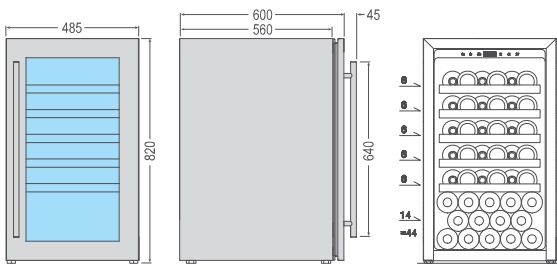

NB: Condensazione statica a parete/fianchi
Wall (sides) static condensation



SOMMELIER 51 PLUS SOMMELIER 51 PLUS FG

MONO TEMPERATURE

ONLY BUILT-IN

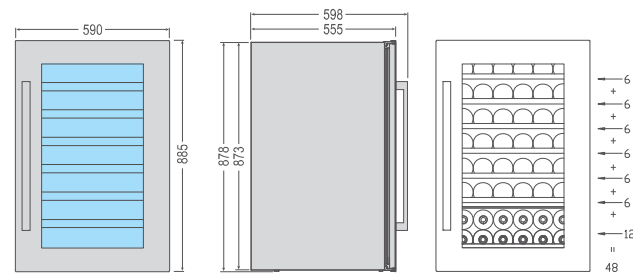

SOMMELIER 52 PLUS SOMMELIER 52 PLUS FG

DUAL TEMPERATURE

ONLY BUILT-IN

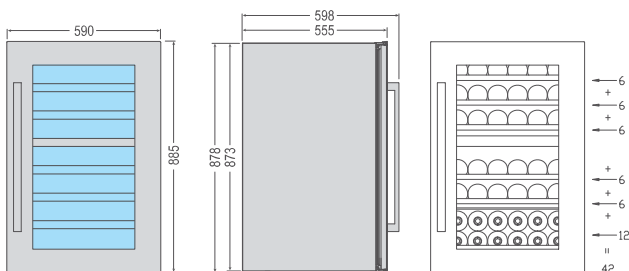

SOMMELIER 80 PLUS

DUAL TEMPERATURE

BUILT-IN & FREE STANDING

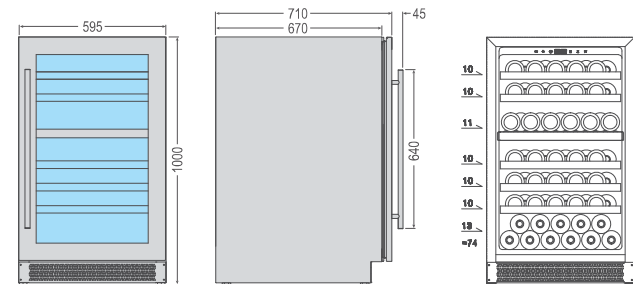

SOMMELIER 80/1 PLUS

MONO TEMPERATURE

BUILT-IN & FREE STANDING

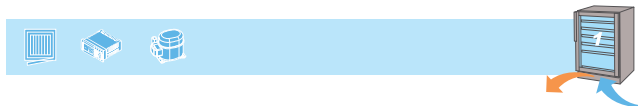
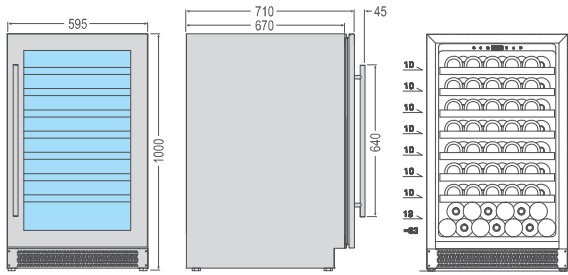

SOMMELIER 351 PLUS

MONO TEMPERATURE

BUILT-IN & FREE STANDING

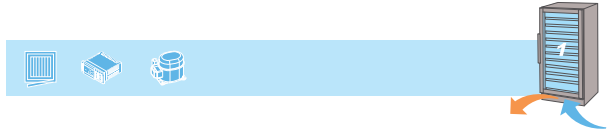
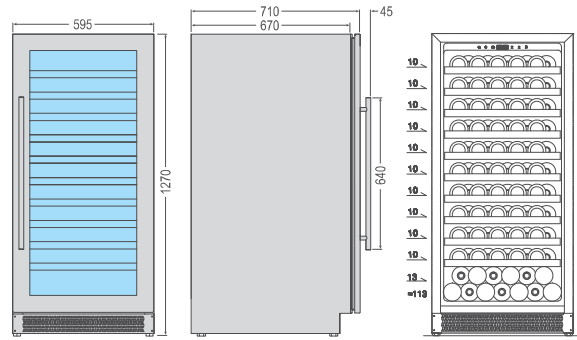

SOMMELIER 352 PLUS

DUAL TEMPERATURE

BUILT-IN & FREE STANDING

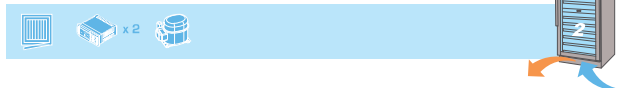
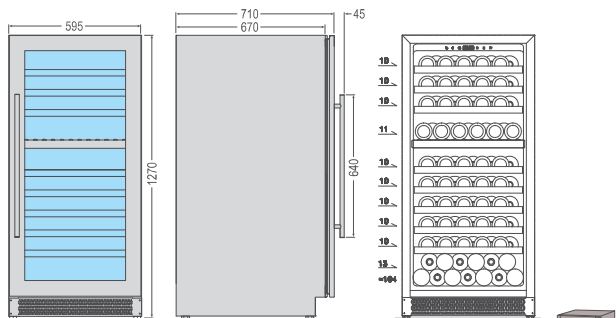

SOMMELIER 401 PLUS

MONO TEMPERATURE

BUILT-IN & FREE STANDING

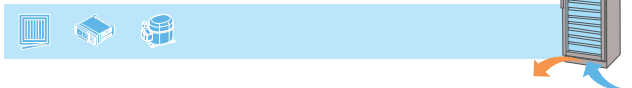
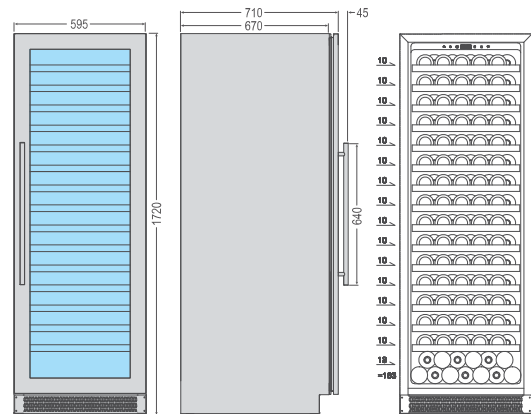

SOMMELIER 402 PLUS

DUAL TEMPERATURE

BUILT-IN & FREE STANDING

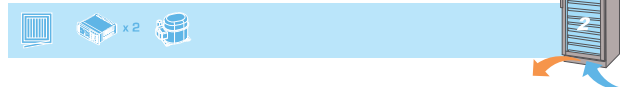
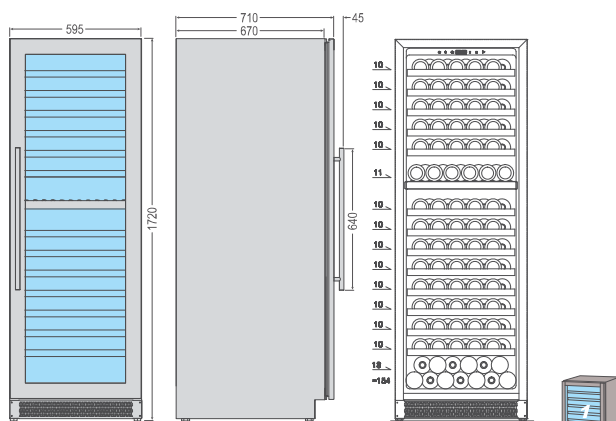





OPTIONAL: Kit unione / Union kit / Kit union / Verbindung kit / Kit uniones



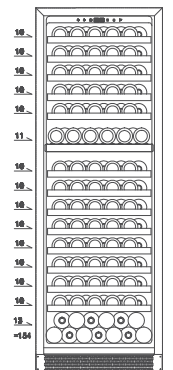
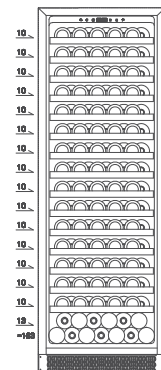





SOMMELIER 401 PLUS



SOMMELIER 402 PLUS



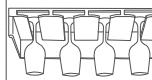

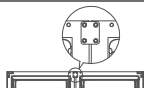
MOD.	LxPxH mm	Kg						
			container n° (20')	container n° (40')	colore colour color			
SOMMELIER 18	645x645x680	32	72	162	COD.13			
SOMMELIER 43/1	640x670x1040	51	54	108	COD.13			
SOMMELIER 43	655x635x1020	48	54	108	COD.13			
SOMMELIER 63	640x670x1240	57	24	51	COD.13			
SOMMELIER 301	640x670x1780	81	24	51	COD.13			
SOMMELIER 302	650x690x1800	98	24	51	COD.13			
SOMMELIER 481	660x750x1950	99	21	45	COD.13			
SOMMELIER 482	660x750x1950	99	21	45	COD.13			
SOMMELIER 24 PLUS	670x640x530	27	81	162				
SOMMELIER 40 PLUS	540x680x870	42	64	136				
SOMMELIER 40/1 PLUS	540x680x870	40	64	136				
SOMMELIER 51 PLUS	592x555x885	43	54	108				

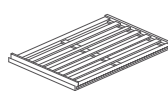
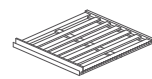
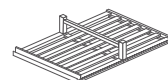
MOD.	LxPxH mm	Kg						
			container n° (20')	container n° (40')	colore colour color			
SOMMELIER 52 PLUS	592x555x885	43	54	108				
SOMMELIER 51 PLUS FG	592x555x885	45	54	108				
SOMMELIER 52 PLUS FG	592x555x885	45	54	108				
SOMMELIER 80 PLUS	660x770x1050	62	48	102				
SOMMELIER 80/1 PLUS	660x770x1050	59	48	102				
SOMMELIER 351 PLUS	650x780x1420	75	27	52				
SOMMELIER 352 PLUS	650x780x1420	78	27	52				
SOMMELIER 401 PLUS	650x780x1870	97	27	52				
SOMMELIER 402 PLUS	650x780x1870	99	27	52				
SOMMELIER 601 PLUS	750x710x2000	143	21	42				
SOMMELIER 602 PLUS	750x710x2000	146	21	42				
SOMMELIER 603 PLUS	750x710x2000	148	21	42				

Accessori - Accessories - Accessoires - Zuberhör - Accessorios		MOD.	 Codice
 <p>Ripiano in legno appendi calici / Wooden shelf for stem glasses / Étagère en bois pour suspendre les verres à pied / Holzregal zum aufhängen der kelchen / Estante de madera donde colgar las copas</p>		SOMMELIER 80 PLUS	Y4003/2
		SOMMELIER 80/1 PLUS	Y4003/2
		SOMMELIER 351 PLUS	Y4003/2
		SOMMELIER 352 PLUS	Y4003/2
		SOMMELIER 401 PLUS	Y4003/2
		SOMMELIER 402 PLUS	Y4003/2
		SOMMELIER 601 PLUS	Y7703/1
		SOMMELIER 602 PLUS	Y7703/1
		SOMMELIER 603 PLUS	Y7703/1
 <p>Ripiano in legno senza guide, con profili in acciaio, per bottiglie inclinate / Wooden shelf without guides, with stainless steel profiles, for sloped bottles / Étagère en bois sans supports, avec profils en acier inoxydable, pour bouteilles inclinées / Holz-regal ohne Führungen, mit Edelstahlprofilen, für Schräglflaschen / Estante de madera sin guías, con perfiles de acero inoxidable, para botellas inclinadas</p>		SOMMELIER 80 PLUS	Y4003/1
		SOMMELIER 80/1 PLUS	Y4003/1
		SOMMELIER 351 PLUS	Y4003/1
		SOMMELIER 352 PLUS	Y4003/1
		SOMMELIER 401 PLUS	Y4003/1
		SOMMELIER 402 PLUS	Y4003/1
		SOMMELIER 601 PLUS	Y020304
SOMMELIER 602 PLUS	Y020304		
SOMMELIER 603 PLUS	Y020304		
 <p>Kit unione / Union kit / Kit union / Verbindung kit / Kit uniones</p>		SOMMELIER 401 PLUS	Y4002/2
		SOMMELIER 402 PLUS	Y4002/2

Optional - Optionnel - Extra - Extras		MOD.
	Kit ripiano estraibile con guide / Kit extractible shelve with guides / Kit étagère extraible avec supports / Kit ausziehbare Rosten mit Führungspaar / Kit estante extraible con guías	LARGE
		SOMMELIER 301
		SOMMELIER 302
		SOMMELIER 481
		SMALL
		SOMMELIER 482
		SOMMELIER 301
		SOMMELIER 302
	Griglia telescopica grande con supporto per bottiglie inclinate / Big sliding shelf with inclined bottles support / Grande grille telescopique avec support pour bouteilles inclinées / Grosse teleskopische Roste mit Unterstützung fuer geneigte Flaschen / Estante deslizablete grande con apoyo para botellas inclinadas	SOMMELIER 481
		SOMMELIER 482
		SOMMELIER 301
		SOMMELIER 302
	Vetri per altitudine / Glasses suitable for altitude / Glaces pour altitude / Für die höhe passende Gläser / Vidrios para altura	SOMMELIER 481
		SOMMELIER 482
		SOMMELIER 18
		SOMMELIER 43/1
		SOMMELIER 43
		SOMMELIER 63

<i>Optional - Optionnel - Extra - Extras</i>		MOD.
	<i>Vetri per altitudine / Glasses suitable for altitude / Glaces pour altitude / Für die höhe passende Gläser / Vidrios para altura</i>	SOMMELIER 301
		SOMMELIER 302
		SOMMELIER 481
		SOMMELIER 482

<i>Optional - Optionnel - Extra - Extras</i>		MOD.
	<i>Supplemento per inversione porta / Supplement for door inversion / Supplément pour inversion de porte / Zuschlag für Türumkehrung / Suplemento para inversión de puertas</i>	<i>Per informazioni vi preghiamo di contattare il nostro ufficio commerciale / For information, please contact our export department / Pour informations, veuillez contacter notre service commercial / Für Informationen kontaktieren Sie bitte unsere Verkaufsabteilung / Si necesita información adicional, no dude en ponerse en contacto con nuestro departamento de venta</i>
	<i>Supplemento per presa elettrica diversa dalla standard / Supplement for electric socket different than the standard / Supplément pour prise électrique différent de la norme / Aufpreis für Steckdose abweichend vom Standard / Suplemento para toma de corriente diferente al estándar</i>	



SOMMELIER 601 PLUS

MARILYN WINE



ESPOSITORE VERTICALE CON INNOVATIVA STRUTTURA PER BOTTIGLIE DI VINO
 VERTICAL DISPLAY WITH INNOVATIVE STRUCTURE FOR WINE BOTTLES

MARILYN 650 WINE

**BUILT-IN &
 FREE STANDING**



A RICHIESTA / ON DEMAND

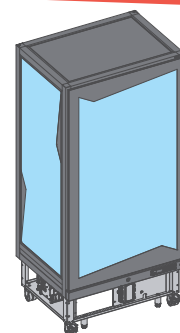

Disponibile in versione SP senza pannelli, da incasso / Available without panels, SP built-in version / Disponible en version SP sans panneaux, version intégrée / Verfügbar in Version SP ohne Platten, Einbau-Version / Disponible en version SP sin paneles



OPTIONAL
 Temperatura di colore LED regola-
 bile tra 3.000 K e 6.500 K
 Adjustable LED color temperature
 between 3.000 K and 6.500 K

Colore standard Standard color		Colori optional Optional colors
COD. 13	COD. 17	COD. 34

- Capacità massima 650 litri e 114 bottiglie di vino da 0,75 cl
- Temperatura regolabile +4/+18°C
- Termodinamica R290 ad alta efficienza
- OPTIONAL: Temperatura di colore LED regolabile tra 3.000 K e 6.500 K
- Elegante telaio in alluminio anodizzato nero
- Porta con vetrocamera strutturale a bassa emissività, con vetri esterni temperati e serigrafati
- Versione cromatica standard: nero
- Interno interamente in acciaio AISI 304 inossidabile anticorrosione, con lavorazione al laser e finitura lucida a specchio
- Centralina touch screen con retroilluminazione ad alto contrasto. Funzioni termometro, comando dell'illuminazione e modalità ECO integrate
- Elegante ed ampia maniglia "a scomparsa", integrata nella struttura lungo l'intera altezza della porta.
- Ruote gemellate pivotanti, di cui due con funzione freno
- Serratura di serie

- Maximum Capacity 650 liters and 114 wine bottles 0,75 cl
- Adjustable temperature + 4 / + 18 ° C
- High efficiency R290 thermodynamics
- OPTIONAL: Adjustable LED color temperature between 3.000 K and 6.500 K
- Elegant frame in black anodized aluminum
- Door with low emissivity structural glass, with tempered and silk-screened outside windows
- Standard color: black
- Interior made entirely of AISI 304 stainless steel, corrosion free, laser cut and mirror polished finish.
- Touch screen controller with high contrast backlight, features to adjust the thermometer, lighting control and integrated ECO mode
- Elegant and wide "hidden" handle, integrated on the full height of the door.
- Chrome stainless steel swivel wheels with and without brake
- Lock as standard

* Versione speciale (con sovrapprezzo) / Special version (with surcharge)



Porta bottiglie in plexiglass / Plexiglass bottle rack

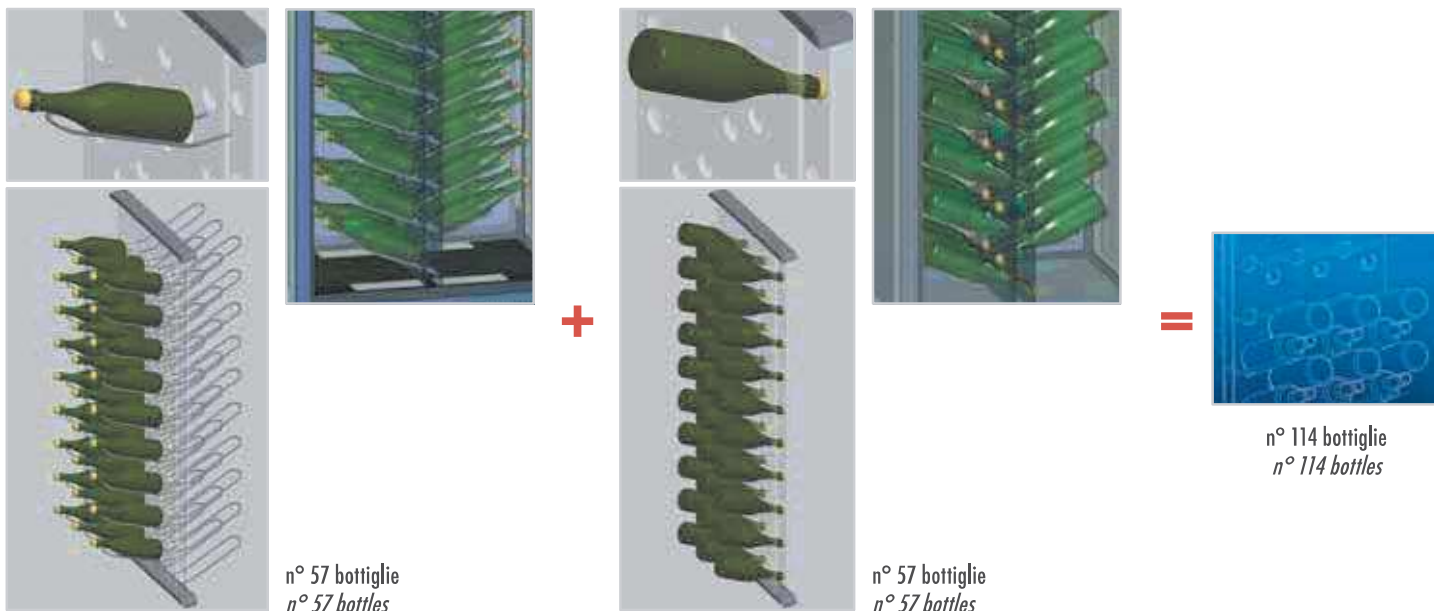

	°C	Lt.	LxPxH mm	N° - mm. STANDARD	Watt	% U.R.	DEFROST	H ₂ O			0,75 Lt.	Kg.		
Marilyn 650 Wine	+4/+18	650	900x710x1910	n° 57 supporti acciaio	400	75		AUT		R290	n° 114 0,75 mm.	240	Standard	LED Standard

Voltaggio di serie - Standard voltage: 230v/1/50Hz • Classe climatica - Climatic class: MAX = (30°C - % U.R. 55)

MARILYN 650 WINE

MARILYN 650 WINE SP

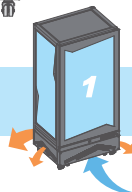
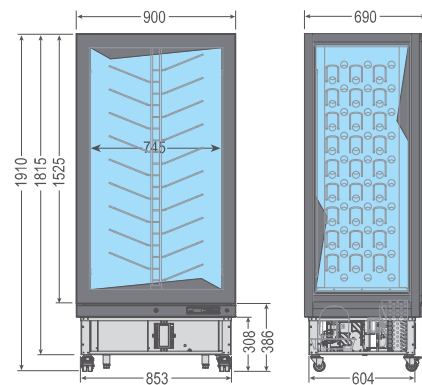
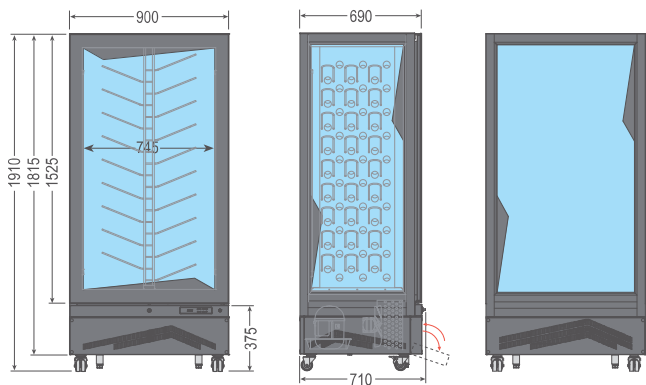

TOUCH SCREEN

MOD.							
	LxPxH mm	Kg	container n°(20°)	container n°(40°)	colore colour color		
MARILYN 650 WINE	980x870x2180	265	10	24	COD.13	COD.17	

Optional - Optionnel - Extra - Extras		MOD.
	Condensazione H2O / Condensation H2O / Condensation H2O / Kondensation H2O / Condensación H2O	MARILYN 650 WINE
	Vetri per altitudine / Glasses suitable for altitude / Glaces pour altitude / Für die höhe passende Gläser / Vidrios para altura	MARILYN 650 WINE
	Vetri a specchio posteriori / Back mirror glasses / Verres miroir arrière / Ruckseitige Spiegelgläser / Vidrios a espejo traseros	MARILYN 650 WINE
	Vetro a specchio laterale / Side mirror glass / Verre miroir latéral / Seiten Spiegelglas / Vidrio a espejo lateral	MARILYN 650 WINE

Optional - Optionnel - Extra - Extras		MOD.
	Supplemento per inversione porta / Supplement for door inversion / Supplément pour inversion de porte / Zuschlag für Türumkehrung / Suplemento para inversión de puertas	Per informazioni vi preghiamo di contattare il nostro ufficio commerciale / For information, please contact our export department / Pour informations, veuillez contacter notre service commercial / Für Informationen kontaktieren Sie bitte unsere Verkaufsabteilung / Si necesita información adicional, no dude en ponerse en contacto con nuestro departamento de venta
	Supplemento per presa elettrica diversa dalla standard / Supplement for electric socket different than the standard / Supplément pour prise électrique différent de la norme / Aufpreis für Steckdose abweichend vom Standard / Suplemento para toma de corriente diferente al estándar	

VINITY



ESPOSITORE componibile per vini MODULAR WINE VERTICAL DISPLAY

VINITY 3 V



- Elegante maniglia in acciaio satinato
- Vetri fumè con filtro anti-UV
- Griglie telescopiche in legno
- LED blu di serie

- Elegant stainless-steel brushed handle
- Smoked glass door with UV-filter
- Wooden sliding shelves
- Blue LED light as standard

** Mensole rimovibili dall'utente per posizionare le bottiglie in posizione verticale

** Client could also remove shelves in order to place bottles in upright position

Classe Energetica
Energy efficiency class:



VINITY 3 O



VINITY 3 V

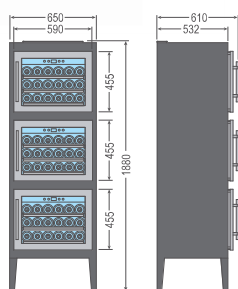

VINITY 3 O

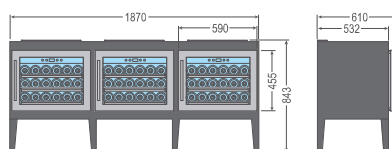

VINITY 4

Esempio di configurazione
Example of configuration

Vinity 4

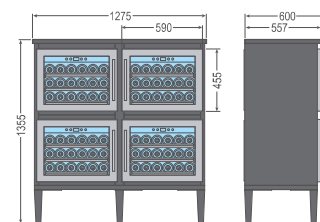

Colore standard
Standard color



Colori optional
Optional colors

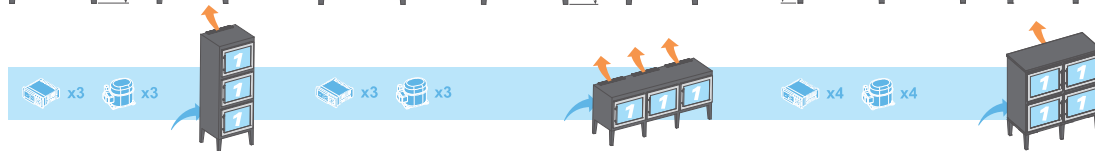

	°C	Lt.	LxPxH mm	N° - mm. STANDARD	Watt	% U.R.	DEFROST	H ₂ O			0,75 Lt.	Kg.		
Vinity 3 V	+5/+20	150	650x610x1880	9 mm. 444x337	210	-	No frost	AUT		R600a	n° 54 Ø 75 mm.	-	-	LED Standard
Vinity 3 O	+5/+20	150	1870x610x843	9 mm. 444x337	210	-	No frost	AUT		R600a	n° 54 Ø 75 mm.	-	-	LED Standard

Voltaggio di serie - Standard voltage: 230v/1/50Hz • Classe climatica - Climatic class: MAX = (30°C - % U.R. 55)

i nostri vini
franciacorta
agno bianco
ribolla
soave classico
lugana
saurignon-
chardonnay
lison
cabernet saurignon
merlot
miglio rosato
prosecco millesimato
rosè extra dry





ENOPRESTIGE



ESPOSITORE VERTICALE IN LEGNO MASSELLO PER VINI
SOLID WOODEN WINE VERTICAL DISPLAY

ENOPRESTIGE 400 4TV/1TV



1 or 4 TEMPERATURE



OPTIONAL RAL

Colori standard Standard colors			Colori optional Optional colors		
COD. 04	COD. 05	COD. 07	RAL	COD. 70	COD. 95

- Temperatura regolabile +5/+16°C (mono o multi temperatura)
- Struttura in legno massello con comoda maniglia in tinta
- Centralina elettronica con display digitale della temperatura più pannello comandi nella parte frontale
- Griglie con profili in legno
- Refrigerazione statica (utilizzo 4 temperature), refrigerazione ventilata (utilizzo unica temperatura)
- Sbrinatorio automatico ed evaporazione automatica acqua sbrinatorio
- Temperatura di colore LED a scelta: 3.000 K o 6.500 K

- Adjustable temperature +5/+16°C (mono or multi temperature)
- Solid wood structure with same color handle
- Electronic temperature control with digital display and control panel in the frontal part
- Shelves with wooden profiles
- Static refrigeration (4 temperatures), ventilated refrigeration (for 1 temperature)
- Automatic defrost and automatic defrosting water
- Color LED temperature at the customer's choice: 3,000 K or 6,500 K

ENOPRESTIGE 600 2TV























2 TEMPERATURES



ENOPRESTIGE 600 5TV

5 TEMPERATURES



	 °C	 Lt.	 LxPxH mm	 N° - mm. STANDARD	 Watt	 % U.R.	 DEFROST	 H ₂ O			 0,75 Lt.	 Kg.		
Enoprestige 300 1TV	+5/+16	300	613x536x1922	4	650	65		AUT		R600a	n° 80 Ø 75 mm.	114	Optional	LED Standard
Enoprestige 400 4TV/1TV	+5/+7/+10/+16 +5/+16	400	827x536x1922	4	650	65		AUT	4 TV  1 TV 	R600a	n° 112 Ø 75 mm.	134	Optional	LED Standard
Enoprestige 600 2TV	+5/+16 +16/+18	600	1201x536x1922	n° 4+4	780	60		AUT		R600a	n° 160 Ø 75 mm.	201	Optional	LED Standard
Enoprestige 600 5TV	+5/+7/+10/+18 +16/+18	600	1201x536x1922	n° 4+4	560	60		AUT		R600a	n° 168 Ø 75 mm.	201	Optional	LED Standard

Voltaggio di serie - Standard voltage: 230v/1/50Hz • Classe climatica - Climatic class: MAX = (30°C - % U.R. 55)



ENOTEC 340 3TV



i OPTIONAL: COD. 01



i OPTIONAL: COD. 02

Printatura colori legno standard Standard decoration wood colors		Colori optional Optional colors		
				
COD. 04	COD. 05	RAL	COD. 02	COD. 01

ENOTEC 680 1TV



ENOTEC 1TV/P



Dotazione interna con SUPPORTI PIANI in lamiera verniciata nera
Internal equipment with FLAT SUPPORTS in black painted sheet



ENOTEC 340 e 680 "1TV-P"
OPTIONAL = Vetro posteriore
OPTIONAL = Back glass

	°C	Lt.	LxPxH mm	N° - mm. STANDARD	Watt	% U.R.	DEFROST	H ₂ O			0,75 Lt.	Kg.		
Enotec 340 1TV	+5/+18	340	595x711x1810	3 mm. 450x526	600	65		AUT		R452A	n° 90 Ø 75 mm.	112	Optional	LED Standard
Enotec 340 3TV	+5/+9/+18	340	595x711x1810	3 mm. 450x526	600	65		AUT		R452A	n° 90 Ø 75 mm.	112	Optional	LED Standard
Enotec 340 1TV/P	+5/+18	340	595x711x1810	3 mm. 470x526	600	65		AUT		R452A	n° 90 Ø 75 mm.	112	Optional	LED Standard
Enotec 680 1TV	+5/+18	680	1000x711x1810	3 mm. 450x929	700	65		AUT		R134a	n° 180 Ø 75 mm.	168	Optional	LED Standard
Enotec 680 3TV	+5/+9/+18	680	1000x711x1810	3 mm. 450x929	700	65		AUT		R134a	n° 180 Ø 75 mm.	168	Optional	LED Standard
Enotec 680 1TV/P	+5/+18	680	1000x711x1810	3 mm. 460x929	700	65		AUT		R134a	n° 180 Ø 75 mm.	168	Optional	LED Standard

Voltaggio di serie - Standard voltage: 230v/1/50Hz • Classe climatica - Climatic class: MAX = (30°C - % U.R. 55)

CANTINETTA / MAXICANTINETTA



MAXICANTINETTA GLX



CANTINETTA GLX



i **OPTIONAL:**
 Kit ventilazione interna / Kit internal ventilation / Kit ventilation interne / Inneres Umluftungskit / Kit ventilacion interna



ACCESSORIO / ACCESSORY:
 Termometro / Thermometer / Thermomètre / Thermometer / Termometro

i Termometro meccanico esterno
 Mechanical external thermometer

Vetri fumè con filtro anti-UV
 Smoked glass door with UV-filter

Griglie in legno
 Wooden shelves

Classe Energetica
 Energy efficiency class:



Colori standard Standard colors			Colori optional Optional colors		
COD. 04	COD. 05	COD. 07	RAL	COD. 70	COD. 95

	°C	Lt.	LxPxH mm	N° - mm. STANDARD	Watt	% U.R.	DEFROST	H ₂ O		R600a	0,75 Lt.	Kg.		LED Standard
Cantinetta GLX	+6/+16	355	695x650x1880	5 mm. 512x395	125	60		AUT		R600a	n° 106 Ø 75 mm.	94	Standard	LED Standard
Maxicantinetta GLX	+6/+16	355+355	1325x650x1880	10 mm. 512x395	250	60		AUT		R600a	n° 106+106 Ø 75 mm.	185	Standard	LED Standard

Voltaggio di serie - Standard voltage: 230v/1/50Hz • Classe climatica - Climatic class: MAX = (30°C - % U.R. 55)

ENOPRESTIGE

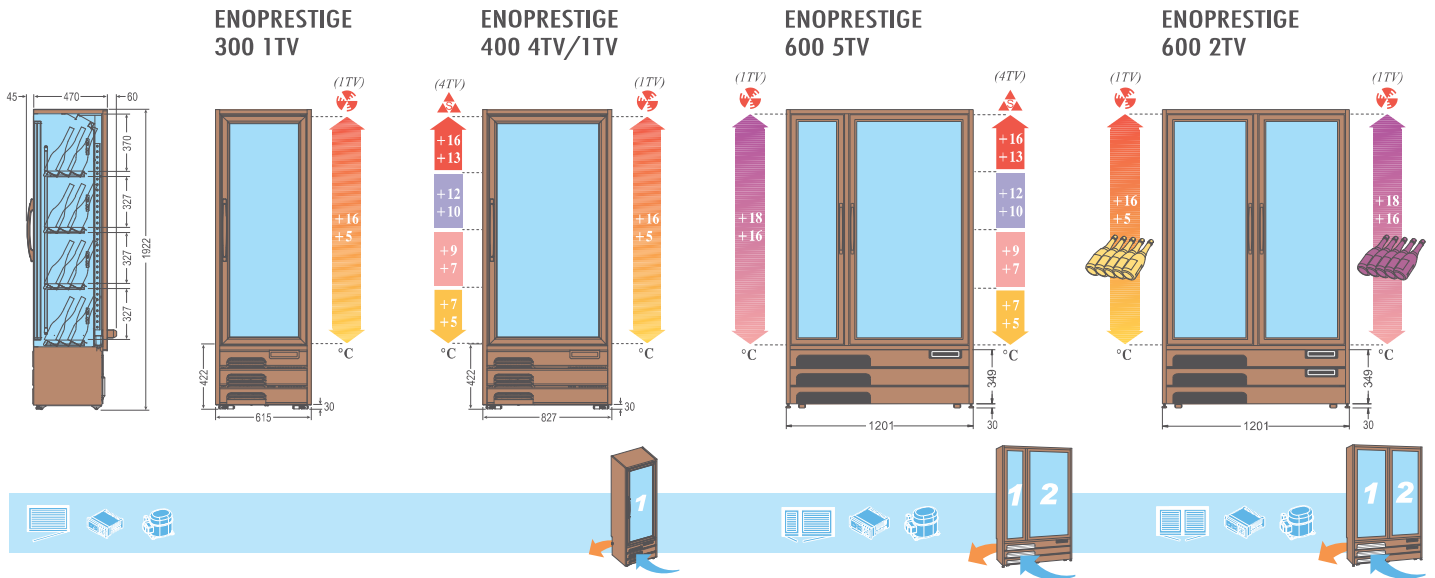

ENOTEC

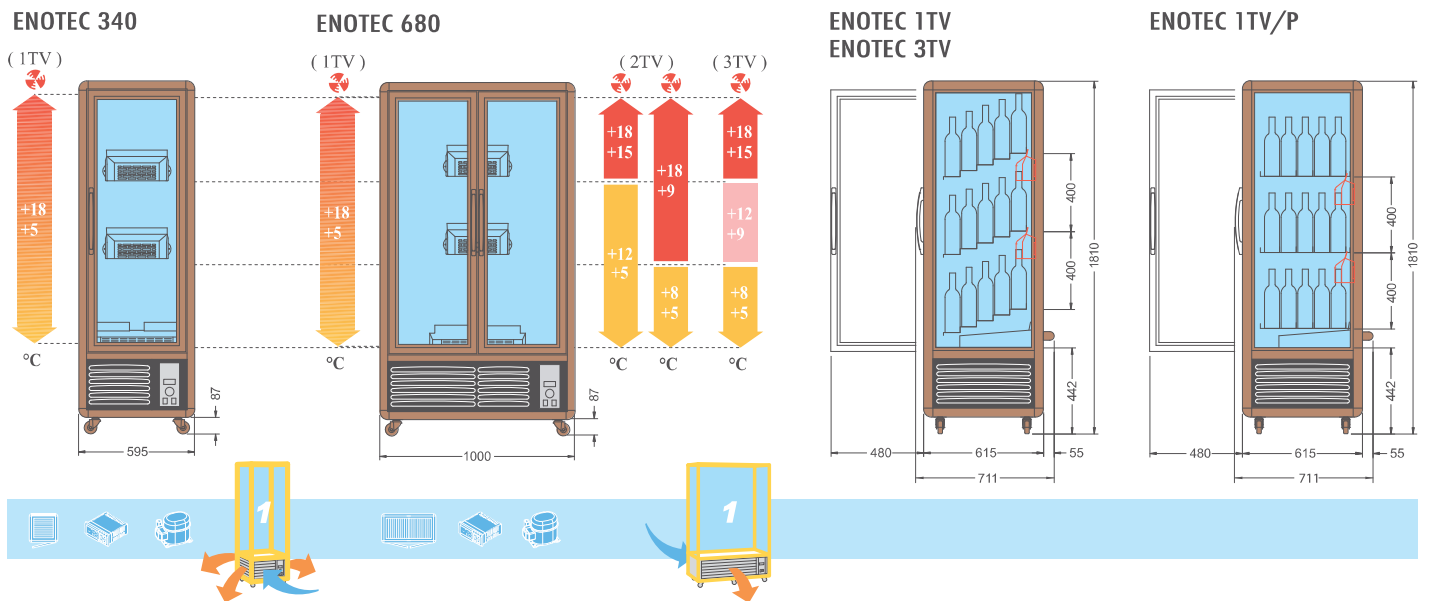

CANTINETTA / MAXICANTINETTA

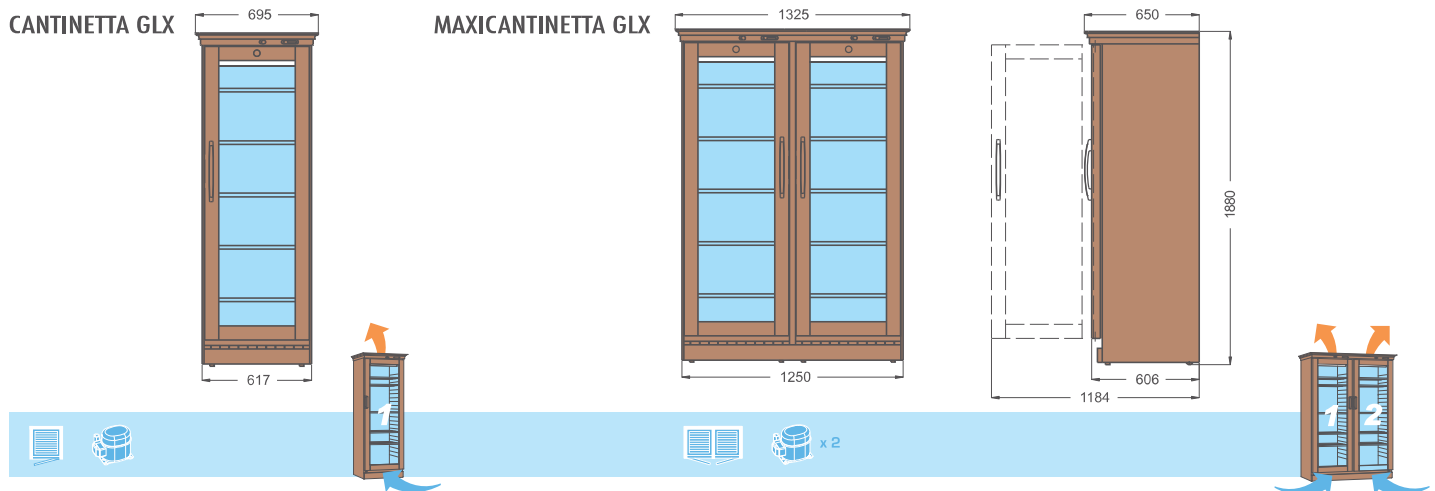

SNELLE WINE SG























SNELLE WINE 200 SG



i SG: senza gruppo refrigerante
 SG: without refrigerating group
 SG: sans le group réfrigérant
 SG: ohne gek. Gruppe
 SG: sin grupo refrigerador

I dati in tabella si riferiscono al gruppo UMC
 The table data are referred to the UMC group.

Colori standard Standard colors	Colori optional Optional colors
 COD. 02	 COD. 01
	 RAL

	 °C	 Lt.	 LxPxH mm	 N° - mm. STANDARD	 Watt	 % U.R.	 DEFROST	 H ₂ O			 0,75 Lt.	 Kg.		
Snelle Wine 200 SG	+4/+10 +5/+16	200	960x350x800	1 mm. 836x205	60	-		MAN		R134a	n° 40 Ø 75 mm.	51	-	Standard
Snelle Wine 250 SG	+4/+10 +5/+16	250	800x400x1075	2 mm. 676x255	60	-		MAN		R134a	n° 72 Ø 75 mm.	61	-	Standard

Voltaggio di serie - Standard voltage: 230v/1/50Hz • Classe climatica - Climatic class: MAX = (30°C - % U.R. 55)

* Produzione a richiesta: per favore contattare l'ufficio commerciale / Production on request: please contact the sales dept.

SNELLE WINE SG

SNELLE WINE 200 SG

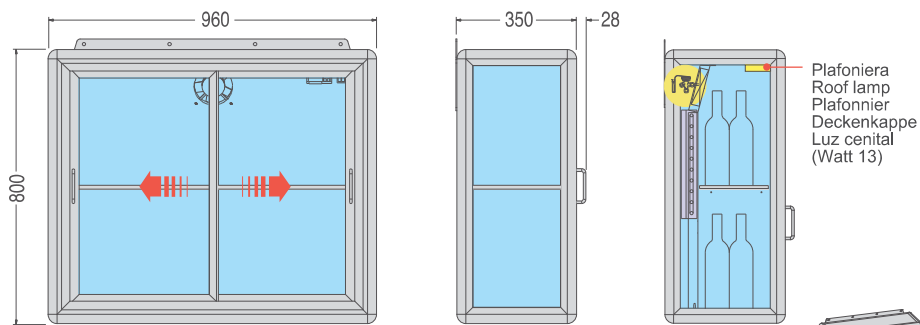

Accessorio: 

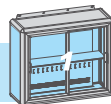

SNELLE WINE 250 SG

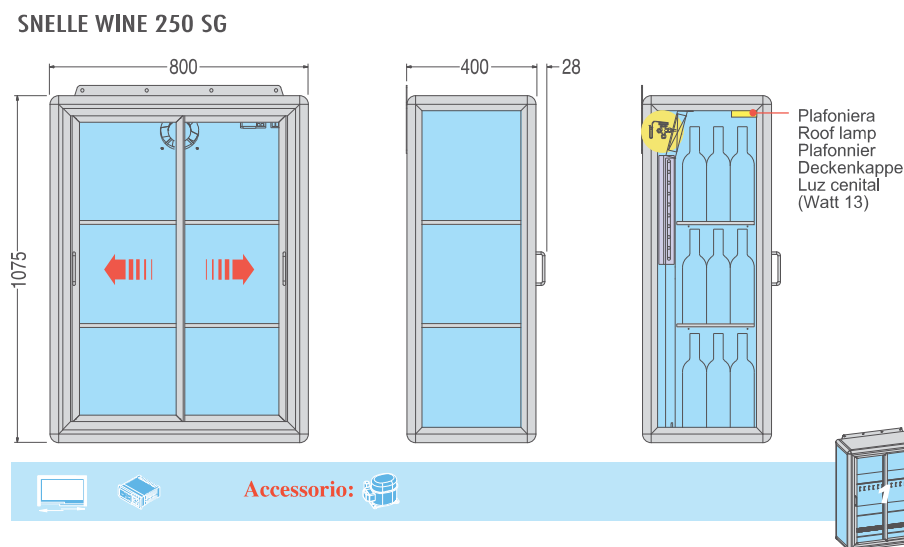

Accessorio: 



OPTIONAL: RAL



Ventilatore
Fan
Ventilateur
Ventilator
Ventilador



Centralina elettronica / Electronic control panel
/ Platine électronique / Elektronisches Gehäuse /
Centralita electrónica

Interruttore 2TV - 1TV
2TV - 1TV switch
Interrupteur 2TV - 1TV
Schalter 2TV - 1TV
Interruptor 2TV - 1TV

Lmax: 5Mt

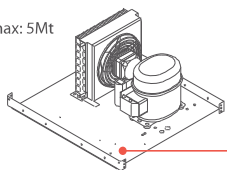

Accessorio:
Gruppo UMC
UMC group
Groupe UMC
Gruppe UMC
Grupo UMC
Watt 650





Sbrinatorio
Defrosting
Dégivrage
Enteisung
Descongelación

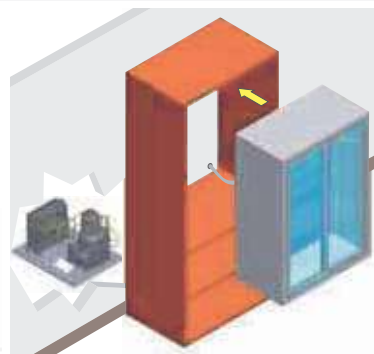



NB:
Uscita tubi di collegamento
sulla schiena.
Output connecting pipes
on the backside.

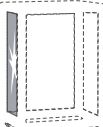
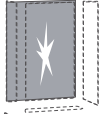

Valvola termostatica
Thermal expansion valve
Vanne thermostatique
Thermostatisches Ventil
Válvula termostática

Optional - Optionnel - Extra - Extras		MOD.
	Condensazione H2O / Condensation H2O / Condensation H2O / Kondensation H2O / Condensación H2O	ENOPRESTIGE 400 4TV/1TV
		ENOPRESTIGE 600 2TV
		ENOPRESTIGE 600 5TV
		ENOTECH 340 1TV
		ENOTECH 340 3TV
		ENOTECH 340 1TV/P
		ENOTECH 680 1TV
		ENOTECH 680 3TV
	Serratura (per ogni porta) / Lock (for every door) / Serrure (pour chaque porte) / Schloss (für jede Tür) / Cerradura (para cada puerta)	ENOPRESTIGE 300 1TV
		ENOPRESTIGE 400 4TV/1TV
		ENOPRESTIGE 600 2TV
		ENOPRESTIGE 600 5TV
		ENOTECH 340 1TV
		ENOTECH 340 3TV
		ENOTECH 340 1TV/P
		ENOTECH 680 1TV
	Valvola solenoide / Solenoid valve / Solenoidventil / Soupape solénoïdale / Válvula solenoide	SNELLE WINE 200 SG
		SNELLE WINE 250 SG
	Vetri per altitudine / Glasses suitable for altitude / Glaces pour altitude / Für die höhe passende Gläser / Vidrios para altura	ENOPRESTIGE 300 1TV
		ENOPRESTIGE 400 4TV/1TV
		ENOPRESTIGE 600 2TV
		ENOPRESTIGE 600 5TV
		ENOTECH 340 1TV
		ENOTECH 340 3TV
		ENOTECH 340 1TV/P
		ENOTECH 680 1TV
		ENOTECH 680 3TV
		ENOTECH 680 1TV/P
		CANTINETTA GLX
		MAXICANTINETTA GLX
		SNELLE WINE 200 SG
SNELLE WINE 250 SG		
	Vetro a specchio laterale / Side mirror glass / Verre miroir latéral / Seiten Spiegelglas / Vidrio a espejo lateral	ENOTECH 340 1TV
		ENOTECH 340 3TV
		ENOTECH 340 1TV/P
		ENOTECH 680 1TV
		ENOTECH 680 3TV
	Vetro posteriore / Back glass	ENOTECH 680 1TV/P
		ENOTECH 340 1TV/P

Optional - Optionnel - Extra - Extras		MOD.
	Supplemento per inversione porta / Supplement for door inversion / Supplément pour inversion de porte / Zuschlag für Türumkehrung / Suplemento para inversión de puertas	Per informazioni vi preghiamo di contattare il nostro ufficio commerciale / For information, please contact our export department / Pour informations, veuillez contacter notre service commercial / Für Informationen kontaktieren Sie bitte unsere Verkaufsabteilung / Si necesita información adicional, no dude en ponerse en contacto con nuestro departamento de venta
	Supplemento per presa elettrica diversa dalla standard / Supplement for electric socket different than the standard / Supplément pour prise électrique différent de la norme / Aufpreis für Steckdose abweichend vom Standard / Suplemento para toma de corriente diferente al estándar	Per informazioni vi preghiamo di contattare il nostro ufficio commerciale / For information, please contact our export department / Pour informations, veuillez contacter notre service commercial / Für Informationen kontaktieren Sie bitte unsere Verkaufsabteilung / Si necesita información adicional, no dude en ponerse en contacto con nuestro departamento de venta