

POS



Refrigeratori per bibite / Coolers for soft drinks / Réfrigérateurs pour boissons / Kühlende Strukturen für Getränke / Refrigerador para bebidas

POS

ACCESSORIO / ACCESSORY



0,50 lt. Pet bottles N° 72
0,33 lt. Cans N° 125

Esterno interno in PVC
Inside outside of PVC
Äusseres und Inneres aus PVC
Extérieur et intérieur en PVC
Exterior interior en PVC



Di serie senza pubblicità
Series Standard with no advertisement
De série sans publicité
Serienmässig ohne Reklame
De serie sin publicidad

Colori standard
Standard colors



POS 2

0,50 lt. Pet bottles N° 84
0,33 lt. Cans N° 144

Di serie senza pubblicità
Series Standard with no advertisement
De série sans publicité
Serienmässig ohne Reklame
De serie sin publicidad

Facilità di applicazione del marchio
Ease of brand application

Refrigeratori open-top
Open-top coolers

Termostato regolabile
Adjustable thermostat

Colori standard
Standard colors

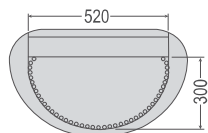
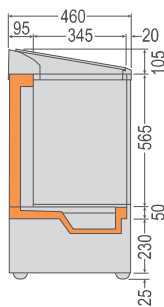
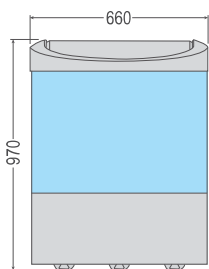

| | °C | Watt | Lt. | STANDARD | DEFROST | H ₂ O | | | mm. (LxPxH) | Kg. | | |
|-------|--------|------|-----|----------|---------|------------------|--|-------|-------------|-----|---|----------|
| POS | +2/+8 | 250 | 70 | - | | AUT | | R600a | 460x615x970 | 55 | - | - |
| POS 2 | +2/+12 | 140 | 103 | - | | AUT | | R600a | 660x460x970 | 31 | - | Standard |

Voltaggio di serie - Standard voltage: 230V/1/50Hz • Classe climatica - Climatic class: MAX = (25°C - % U.R. 60)

SERIE AB - ABX



Congelatori industriali / Freezers for the industry / Congélateurs industriels / Gewerbliche-Tiefkühlgeräte / Congeladores industriales

AB 300



Cesti di serie
Serial baskets
Paniers de serie
Serien Koerbe
Cestas de serie



AB 108 - 200 - 240 - 300 - 350 - 396 - 425 - 506:

Esterno in acciaio zincato verniciato bianco. Interno in alluminio grigio
/ Outside in galvanized white painted steel. Inside in gray aluminum / Extérieur en acier peint en blanc galvanisé. Intérieur en aluminium gris / Außen aus verzinktem, weiß lackiertem Stahl. Innen aus grauem Aluminium / Exterior de acero galvanizado pintado blanco. Interior de aluminio gris

AB 530 - 610 - 710:

Esterno in acciaio stampato rivestito. Interno in acciaio bianco verniciato a polvere. Robusto e antigraffio.
Outside in coated printed steel plate. Inside in sturdy and scratch resistant powder coated white steel

Colori standard
Standard colors

COD. 09

| | °C | Watt | Lt. | STANDARD | Max | DEFROST | H ₂ O | | | mm. (LxPxH) | Kg. | | | |
|--------|---------|------|-----|----------|------|---------|------------------|--|-------|--------------|-----|----------|----------|---|
| AB 108 | -16/-24 | 75 | 101 | n° 1 | n° 2 | | MAN | | R600a | 550x600x825 | 28 | - | - | 1 |
| AB 200 | -16/-26 | 120 | 181 | n° 1 | n° 1 | | MAN | | R600a | 720x695x850 | 40 | Standard | Standard | 1 |
| AB 240 | -16/-26 | 125 | 225 | n° 1 | n° 2 | | MAN | | R600a | 850x695x850 | 44 | Standard | Standard | 1 |
| AB 300 | -16/-26 | 130 | 282 | n° 1 | n° 3 | | MAN | | R600a | 1020x695x850 | 50 | Standard | Standard | 1 |
| AB 350 | -16/-26 | 135 | 317 | n° 1 | n° 3 | | MAN | | R600a | 1125x695x850 | 52 | Standard | Standard | 1 |
| AB 396 | -17/-24 | 145 | 362 | n° 2 | n° 4 | | MAN | | R600a | 1260x695x850 | 55 | Standard | Standard | 1 |
| AB 425 | -16/-26 | 140 | 399 | n° 2 | n° 4 | | MAN | | R600a | 1370x695x850 | 58 | Standard | Standard | 1 |
| AB 506 | -16/-26 | 190 | 463 | n° 2 | n° 5 | | MAN | | R600a | 1560x695x850 | 60 | Standard | Standard | 1 |
| AB 530 | -12/-25 | 173 | 504 | n° 3 | n° 4 | | MAN | | R600a | 1500x730x873 | 67 | Standard | Standard | 1 |
| AB 610 | -12/-25 | 226 | 580 | n° 3 | n° 5 | | MAN | | R600a | 1700x730x873 | 77 | Standard | Standard | 1 |
| AB 710 | -12/-25 | 276 | 670 | n° 3 | n° 6 | | MAN | | R600a | 1800x770x873 | 85 | Standard | Standard | 1 |

Voltaggio di serie - Standard voltage: 230v/1/50Hz • Classe climatica - Climatic class: MAX = (30°C - % U.R. 55)

Congelatori industriali di grande capacità / Big capacity freezers for the industry / Congelateurs industriels de grande capacité / Gewerbliche-Tiefkühlgeräte von großer Kapazität / Congeladores industriales de grande capacidad

AB 780

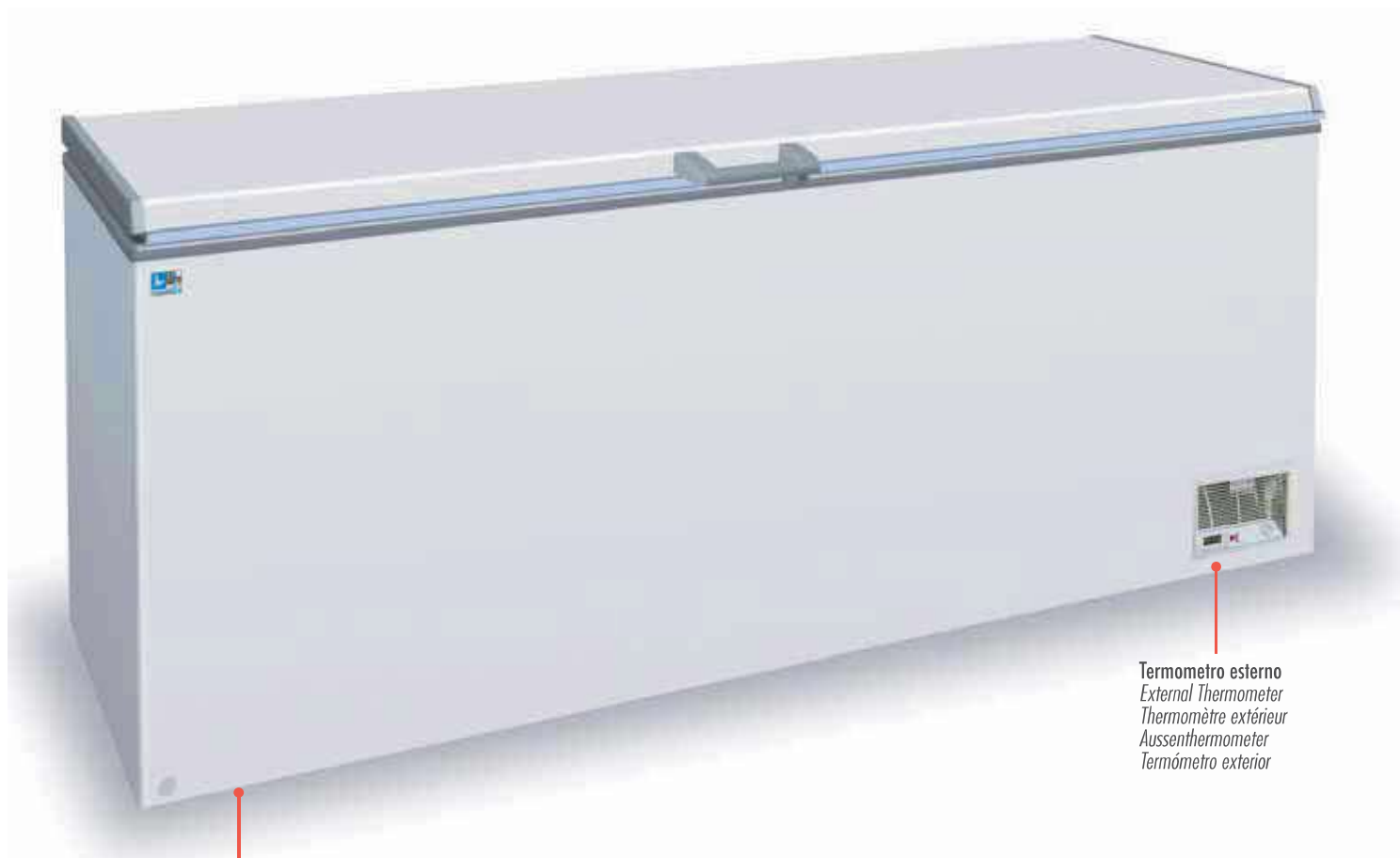

N° 6 ruote di serie
N° 6 standard wheels

Termometro esterno
External Thermometer
Thermomètre extérieur
Aussenthermometer
Termómetro exterior

AB 780:
Esterno in acciaio rivestito bianco. Interno in alluminio
Outside made of white coated steel. Inside aluminium



Spessore di isolamento mm. 75
Insulation thickness 75 mm.
Epaisseur d'isolation 75 mm.
Isolierstärke 75 mm.
Espesor de aislamiento 75 mm.

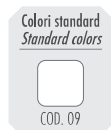

| | °C | Watt | Lt. | STANDARD | Max | DEFROST | H ₂ O | | | mm. (LxPxH) | Kg. | | | |
|--------|---------|------|-----|----------|------|---------|------------------|--|------|--------------|-----|----------|---|---|
| AB 780 | -16/-22 | 300 | 768 | n° 2 | n° 6 | | MAN | | R290 | 1849x743x832 | 97 | Standard | - | 1 |

Voltaggio di serie - Standard voltage: 230v/1/50Hz • Classe climatica - Climatic class: MAX = (30°C - % U.R. 55)

ABX 530
ABX 610
ABX 710

ABX
Porta in acciaio inox
Stainless steel door / Porte en inox
Tür aus Inox / Puerta en acero inox



ABX 530 - 610 - 710:
Porta in acciaio inox. Esterno in acciaio stampato rivestito. Interno in acciaio bianco verniciato a polvere. Robusto e anti graffio.
Stainless steel door. Outside in coated printed steel plate. Inside in sturdy and scratch resistant powder coated white steel

ABX 920:
Porte in acciaio inox. Esterno in acciaio rivestito. Interno in alluminio.
Stainless steel doors. Outside in coated steel plate. Inside in aluminium.

PORTA ACCIAIO INOX
IDEALE PER PICCOLE
PREPARAZIONI DI PIATTI

STAINLESS STEEL LID
FOR PREPARING FOOD



Congelatori industriali
Freezers for the industry
Congélateurs industriels
Gewerbliche-Tiefkühlgeräte
Congeladores industriales

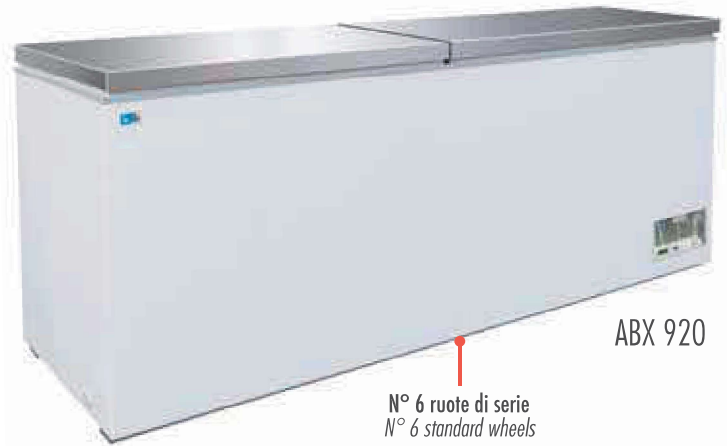
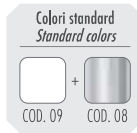

ABX 920

N° 6 ruote di serie
N° 6 standard wheels



ABX
Porta in acciaio inox
Stainless steel door
Porte en inox
Tür aus Inox
Puerta en acero inox

Acciaio verniciato grigio
Grey painted stainless steel
Acier verni en gris
Stahl grau lackiert
Acero pintado de color gris

Colori standard
Standard colors



ABX 396
ABX 506

Esterno in acciaio verniciato grigio. Interno in alluminio grigio
/ Outside made of grey painted steel. Inside gray aluminium /
Extérieur en acier peint en gris. Intérieur en aluminium gris /
Außenfläche aus graulackiertem Stahl. Innenfläche aus grauem Aluminium /
Externo de acero pintado gris. Interno de aluminio gris



Cesti di serie
Serial baskets
Paniers de serie
Serien Koerbe
Cestas de serie

| | °C | Watt | Lt. | STANDARD | Max | DEFROST | H ₂ O | | mm. (LxPxH) | Kg. | | | | |
|---------|---------|------|-----|----------|------|---------|------------------|--|-------------|--------------|-----|----------|----------|---|
| ABX 396 | -17/+24 | 145 | 362 | n° 2 | n° 4 | | MAN | | R600a | 1260x695x850 | 55 | Standard | Standard | 1 |
| ABX 506 | -17/+24 | 190 | 463 | n° 2 | n° 5 | | MAN | | R600a | 1560x695x850 | 60 | Standard | Standard | 1 |
| ABX 530 | -12/+25 | 173 | 504 | n° 3 | n° 4 | | MAN | | R600a | 1500x730x873 | 67 | Standard | Standard | 1 |
| ABX 610 | -12/+25 | 226 | 580 | n° 3 | n° 5 | | MAN | | R134a | 1700x730x873 | 77 | Standard | Standard | 1 |
| ABX 710 | -12/+25 | 276 | 670 | n° 3 | n° 6 | | MAN | | R600a | 1800x770x873 | 85 | Standard | Standard | 1 |
| ABX 920 | -16/+22 | 500 | 980 | n° 2 | n° 7 | | MAN | | R290 | 2200x783x832 | 125 | - | - | 1 |

Voltaggio di serie - Standard voltage: 230v/1/50Hz • Classe climatica - Climatic class: MAX = (32°C - % U.R. 55)

AB / ABX

AB-ABX 200 / 240 / 300 / 350 / 396 / 425 / 506:

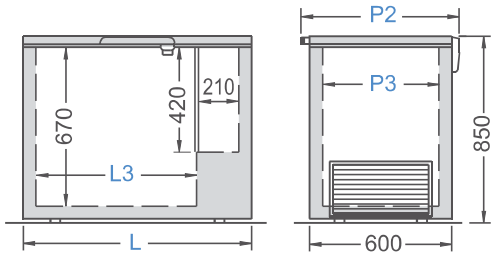

AB-ABX 530 / 610 / 710:

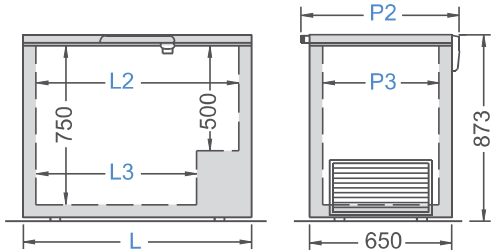

DIMENSIONI

SIZE / DIMENSIONS / MABE / MEDIDAS

| | L (mm) | L2 (mm) | L3 (mm) | P2 (mm) | P3 (mm) |
|----------------|-----------|------------|------------|------------|------------|
| AB 200 | 720 | - | 410 | 695 | 500 |
| AB 240 | 850 | - | 540 | 695 | 500 |
| AB 300 | 1020 | - | 710 | 695 | 500 |
| AB 350 | 1125 | - | 815 | 695 | 500 |
| AB 396/ABX 396 | 1260 | - | 950 | 695 | 500 |
| AB 425/ABX 425 | 1370 | - | 1060 | 695 | 500 |
| AB 506/ABX 506 | 1560 | - | 1250 | 695 | 500 |
| AB 530/ABX 530 | 1500 | 1386 | 1186 | 730 | 536 |
| AB 610/ABX 610 | 1700 | 1586 | 1386 | 730 | 536 |
| AB 710/ABX 710 | 1800 | 1686 | 1486 | 770 | 576 |

Termometro esterno / External Thermometer
Thermomètre extérieur / Aussenthermometer / Termómetro exterior

*** AB 108** Termometro interno
Internal Thermometer
Thermomètre intérieur
Innen thermometer
Termómetro interior

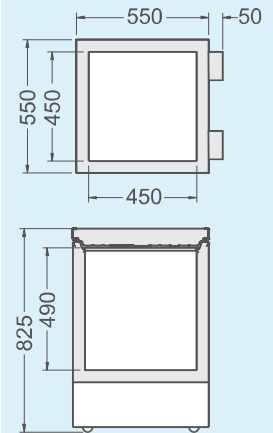

AB 780

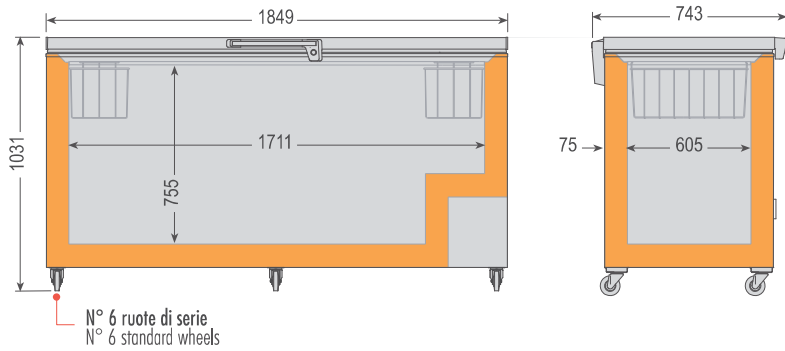

| | |
|--|--|
| | Nr. cesti di serie No. serial baskets Nr. paniers de serie Nr. serien Korbbe Nr. canastos de serie |
| | N° 2 mm. 642x265 h. 260 |
| | Capacità totale cesti Total capacity of baskets Capacité totale paniers Totale kapacitet Korbbe Capacitat total canastos |
| | N° 6 mm. 642x265 h. 260 |

ABX 920

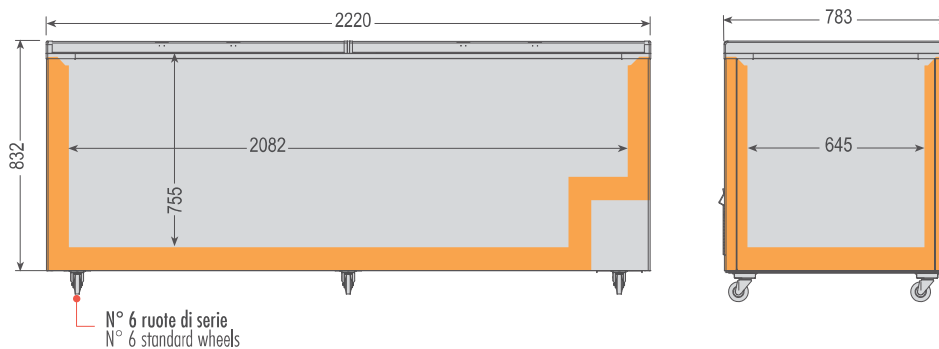

| | |
|--|--|
| | Nr. cesti di serie No. serial baskets Nr. paniers de serie Nr. serien Korbbe Nr. canastos de serie |
| | N° 2 mm. 682x265 h. 260 |
| | Capacità totale cesti Total capacity of baskets Capacité totale paniers Totale kapacitet Korbbe Capacitat total canastos |
| | N° 7 mm. 682x265 h. 260 |

SERIE SB



SB 400



Esterno in acciaio verniciato bianco. Interno in alluminio
Outside made of white painted steel. Inside aluminium
Extérieur en acier peint en blanc. Intérieur en aluminium
Außenfläche aus weißlackiertem Stahl. Innenfläche aus Aluminium
Externo de acero pintado blanco. Interno de aluminio

Spessore isolamento 80 mm.
Insulation thickness 80 mm.
Epaisseur isolation 80 mm.
Isolierung Stärke 80 mm.
Espesor aislamiento 80 mm.

Colori standard
 Standard colors



COD. 09



Cesti di serie / Serial baskets / Paniers de serie
Serien Koerbe / Cestas de serie



Termometro analogico esterno
 External analog thermometer



Basso consumo di energia / Low energy consumption /
Consommation d'énergie modérée / Geringer Energieverbrauch
 / Bajo consumo de energía

| | °C | Watt | Lt. | STANDARD | Max | DEFROST | H ₂ O | | | mm. (LxPxH) | Kg. | | | |
|--------|---------|------|-----|-----------------|------------|---------|------------------|--|-------|--------------|-----|----------|----------|---|
| SB 200 | -18/-24 | 75 | 189 | n° 2 | n° 6 | | MAN | | R600a | 920x650x860 | 53 | Standard | Standard | 1 |
| SB 300 | -18/-24 | 95 | 284 | n° 4 | n° 12 | | MAN | | R600a | 1260x650x860 | 62 | Standard | Standard | 1 |
| SB 400 | -18/-24 | 110 | 368 | n° 5 | n° 15 | | MAN | | R600a | 1560x650x860 | 70 | Standard | Standard | 1 |

Voltaggio di serie - Standard voltage: 230v/1/50Hz • Classe climatica - Climatic class: MAX = (25°C - % U.R. 60)

SERIE SE



SE 325



Esterno in acciaio verniciato bianco. Interno in alluminio
Outside made of white painted steel. Inside aluminium
Extérieur en acier peint en blanc. Intérieur en aluminium
Außenfläche aus weißlackiertem Stahl. Innenfläche aus Aluminium
Externo de acero pintado blanco. Interno de aluminio

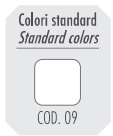

Ampia maniglia con serratura di serie
Large handle with standard lock

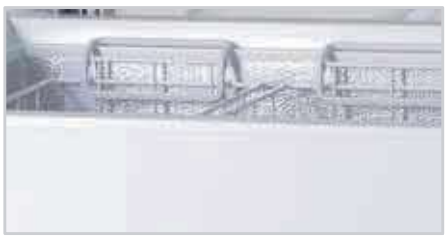

Interno in alluminio
Inside made of aluminum



Termometro analogico esterno
External analog thermometer

| | °C | Watt | Lt. | STANDARD | Max | DEFROST | H ₂ O | | | mm. (LxPxH) | Kg. | | | | |
|--------|---------|------|-----|----------|-------|---------|------------------|--|--|-------------|--------------|----|----------|----------|---|
| SE 255 | -17/-24 | 75 | 244 | n° 2 | n° 9 | | MAN | | | R600a | 1260x600x850 | 61 | Standard | Standard | 1 |
| SE 325 | -17/-24 | 75 | 321 | n° 3 | n° 15 | | MAN | | | R600a | 1560x600x850 | 68 | Standard | Standard | 1 |

Voltaggio di serie - Standard voltage: 230v/1/50Hz • Classe climatica - Climatic class: MAX = (25°C - % U.R. 60)

SB

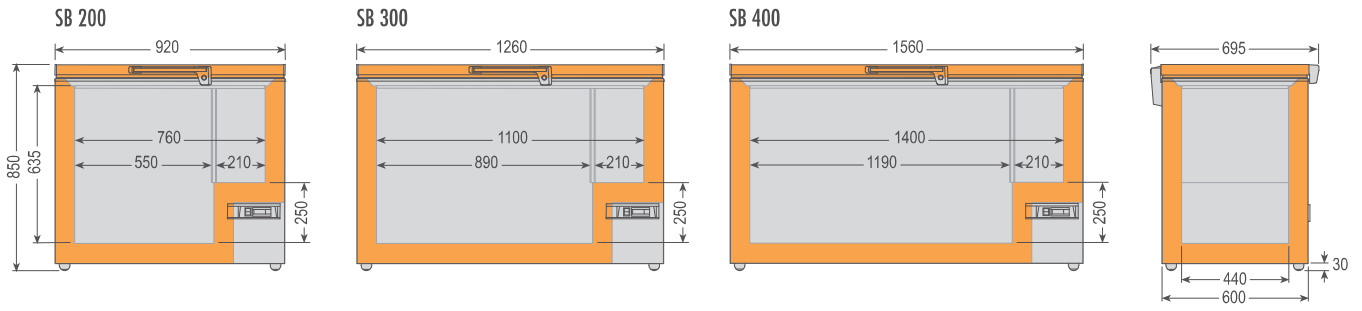

SE

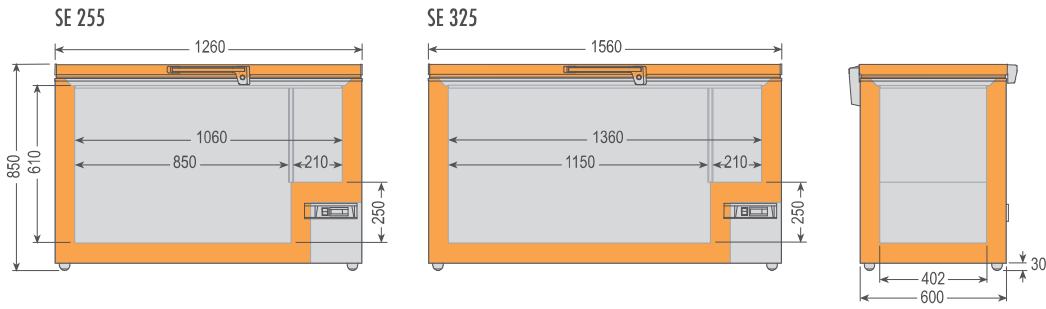



Raffreddatore professionale di grande capacita per bibite / Big capacity professional cooler for soft drinks / Réfrigérateur professionnel pour boissons de grande capacité / Professionelle kühlende Struktur von großer Fähigkeit für Getränke / Refrigerador profesional de grand capacidad para bebidas

RABI 300

Termometro meccanico esterno
 External mechanical thermometer
 Thermomètre mécanique externe
 Externe Mechanischer Thermometer
 Exteriores termómetro mecánico



DI SERIE/STANDARD:
 Ruote / Wheels / Roues
 Räder / Ruedas

Esterno in lamiera verniciata bianco
 Exterior in white painted plate
 Extérieur en tôle verni en blanc
 Aussenseite aus lackiertem weiß Blech
 Exterior en chapa barnizada blanco

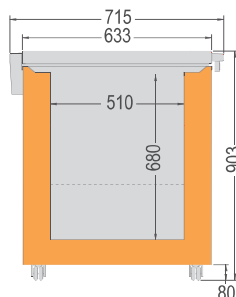
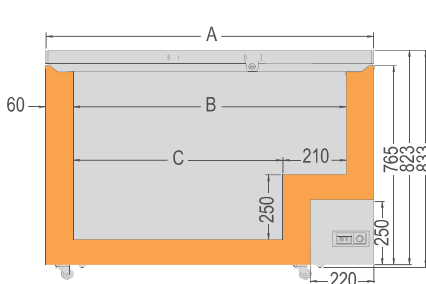

DIMENSIONI
 SIZE / DIMENSIONS / MABE / MEDIDAS

| | A (mm) | B (mm) | C (mm) |
|-----------------|-----------|-----------|-----------|
| RABI 300 | 1012 | 890 | 680 |
| RABI 400 | 1302 | 1180 | 970 |
| RABI 500 | 1552 | 1430 | 1220 |

| | °C | Watt | Lt. | STANDARD | Max | DEFROST | H ₂ O | | mm. (LxPxH) | Kg. | | | |
|-----------------|--------|------|-----|----------|-----|---------|------------------|--|--------------------|-----|----------|----------|---|
| RABI 300 | +1/+10 | 340 | 283 | - | - | | MAN | | R134a 1012x715x903 | 58 | Standard | Standard | 1 |
| RABI 400 | +1/+10 | 350 | 384 | - | - | | MAN | | R134a 1302x715x903 | 65 | Standard | Standard | 1 |
| RABI 500 | +1/+10 | 385 | 471 | - | - | | MAN | | R134a 1552x715x903 | 76 | Standard | Standard | 1 |

Voltaggio di serie - Standard voltage: 230v/1/50Hz • Classe climatica - Climatic class: MAX = (30°C - % U.R. 55)

SERIE FKG



Refrigeratori per bibite / Coolers for soft drinks / Réfrigérateurs pour boissons / Kühlende Strukturen für Getränke / Refrigerador para bebidas

FKG 530

DI SERIE/STANDARD:

Ruote / Wheels / Roues
Räder / Ruedas

Termometro esterno
External Thermometer
Thermomètre extérieur
Aussen thermometer
Termómetro exterior

Esterno in acciaio verniciato bianco. Interno in acciaio grigio
Outside made of white painted steel. Internally grey steel / Ex-
térieur en acier peint en blanc. Intérieur en acier gris / Außenfläche
aus weißlackiertem Stahl. Innenteil aus grauem Stahl / Externo de
acero pintado blanco. Interior en acero gris

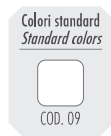

FKGR 273

DI SERIE/STANDARD:

Apribottiglie
Bottle opener
Décapsuleur
Flaschenöffner
Sacacorchos

Termometro esterno
External Thermometer
Thermomètre extérieur
Aussen thermometer
Termómetro exterior

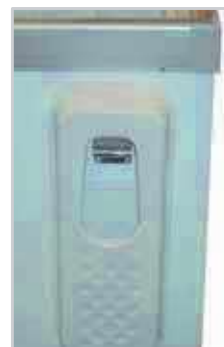
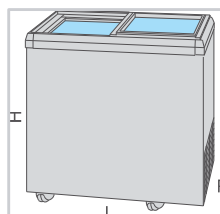

Esterno in acciaio verniciato bianco. Interno in acciaio grigio
Outside made of white painted steel. Internally grey steel / Ex-
térieur en acier peint en blanc. Intérieur en acier gris / Außenfläche
aus weißlackiertem Stahl. Innenteil aus grauem Stahl / Externo de
acero pintado blanco. Interior en acero gris



DI SERIE/STANDARD:

Ruote / Wheels / Roues
Räder / Ruedas

| | °C | Watt | Lt. | STANDARD | Max | DEFROST | H ₂ O | | | mm. (LxPxH) | Kg. | | | |
|----------|--------|------|-----|----------|-----|---------|------------------|--|-------|--------------|-----|---|---|---|
| FKG 530 | +2/+8 | 200 | 441 | - | 4 | | MAN | | R134a | 1504x654x916 | 67 | - | - | 1 |
| FKG 610 | +2/+8 | 226 | 509 | - | 4 | | MAN | | R134a | 1704x654x916 | 77 | - | - | 1 |
| FKGR 273 | +3/+10 | 170 | 210 | - | 6 | | MAN | | R134a | 920x600x895 | 60 | - | - | 1 |
| FKGR 403 | +3/+10 | 260 | 307 | - | 12 | | MAN | | R134a | 1260x600x895 | 72 | - | - | 1 |

Voltaggio di serie - Standard voltage: 230v/1/50Hz • Classe climatica - Climatic class: MAX = (30°C - % U.R. 55)



Espositori e conservatori per gelato / Display cases and freezers for ice cream / Comptoir de présentoir et conservateur à glace / Aussteller und Gefriertruhen für Eis / Expositores y conservadores para helado

FVS 500

Termometro meccanico esterno / External mechanical thermometer
 Thermomètre mécanique externe / Externe Mechanischer Thermometer
 Exteriores termómetro mecánico



DI SERIE/STANDARD:
 Ruote / Castors / Roues
 Räder / Ruedas

Esterno in lamiera verniciata bianco
 Exterior in white painted plate
 Extérieur en tôle verni en blanc
 Aussenseite aus lackiertem weiß Blech
 Exterior en chapa barnizada blanco

Unità condensatrice estraibile
 Extractible condensing unit
 Unité condensatrice pouvant s'extraire
 Ausziehbare Kondenseinheit
 Unidad condensadora extraíble

Colori standard
 Standard colors



Spessore di isolamento mm. 60
 Insulation thickness 60 mm.
 Épaisseur d'isolation 60 mm.
 Isolierstärke 60 mm.
 Espesor de aislamiento 60 mm.

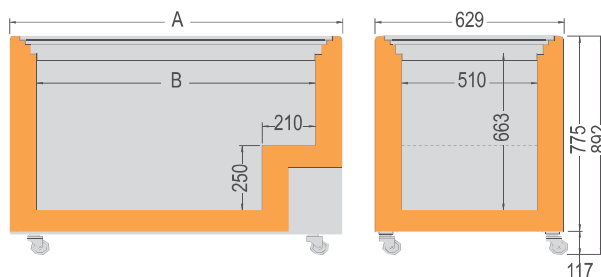

DIMENSIONI / SIZE /
 DIMENSIONS / MABE / MEDIDAS

| | A (mm) | B (mm) |
|---------|-----------|-----------|
| FVS 200 | 719 | 600 |
| FVS 300 | 1009 | 890 |
| FVS 400 | 1298 | 1180 |
| FVS 500 | 1548 | 1430 |
| FVS 700 | 2055 | 1930 |

| | °C | Watt | Lt. | STANDARD | Max | DEFROST | H ₂ O | | mm. (LxPxH) | Kg. | | | |
|---------|---------|------|-----|----------|------|---------|------------------|-------|--------------|-----|----------|---|---|
| FVS 200 | -12/-22 | 190 | 165 | - | n° 2 | MAN | MAN | R600a | 719x629x892 | 47 | Standard | - | 1 |
| FVS 300 | -12/-22 | 220 | 255 | - | n° 3 | MAN | MAN | R290 | 1009x629x892 | 56 | Standard | - | 1 |
| FVS 400 | -12/-22 | 300 | 325 | - | n° 5 | MAN | MAN | R290 | 1298x629x892 | 65 | Standard | - | 1 |
| FVS 500 | -12/-22 | 400 | 430 | - | n° 6 | MAN | MAN | R290 | 1548x629x892 | 85 | Standard | - | 1 |
| FVS 700 | -12/-22 | 440 | 620 | - | n° 8 | MAN | MAN | R290 | 2055x629x892 | 99 | Standard | - | 1 |

Voltaggio di serie - Standard voltage: 230v/1/50Hz • Classe climatica - Climatic class: MAX = (30°C - % U.R. 55)



Congelatori industriali / Freezers for the industry / Congélateurs industriels / Gewerbliche-Tiefkühlgeräte / Congeladores industriales

FIVS 300



Termometro meccanico esterno
 External mechanical thermometer
 Thermomètre mécanique externe
 Externe Mechanischer Thermometer
 Exteriores termómetro mecánico

Esterno in lamiera verniciata bianco
 Exterior in white painted plate
 Extérieur en tôle verni en blanc
 Aussenseite aus lackiertem weiß Blech
 Exterior en chapa barnizada blanco

DI SERIE/STANDARD:
 Ruote / Castors / Roues
 Räder / Ruedas

Colori standard
 Standard colors



Spessore di isolamento mm. 60
 Insulation thickness 60 mm.
 Epaisseur d'isolation 60 mm.
 Isolerstärke 60 mm.
 Espesor de aislamiento 60 mm.

| DIMENSIONI / SIZE / DIMENSIONS / MABE / MEDIDAS | A (mm) | B (mm) |
|--|-----------|-----------|
| FIVS 200 | 720 | 600 |
| FIVS 300 | 1009 | 890 |
| FIVS 400 | 1298 | 1180 |
| FIVS 500 | 1548 | 1430 |

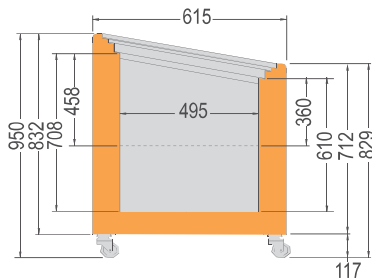
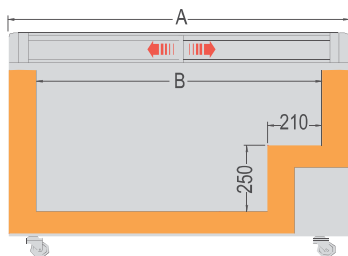

FIVS 200



| | °C | Watt | Lt. | STANDARD | Max | DEFROST | H ₂ O | | | mm. (LxPxH) | Kg. | | | |
|----------|---------|------|-----|----------|------|---------|------------------|--|-------|--------------|-----|----------|---|---|
| FIVS 200 | -12/-22 | 190 | 157 | - | n° 2 | | MAN | | R600a | 720x615x950 | 45 | Standard | - | 1 |
| FIVS 300 | -12/-22 | 220 | 238 | - | n° 3 | | MAN | | R290 | 1009x615x950 | 56 | Standard | - | 1 |
| FIVS 400 | -12/-22 | 300 | 325 | - | n° 5 | | MAN | | R452A | 1298x615x950 | 65 | Standard | - | 1 |
| FIVS 500 | -12/-22 | 400 | 398 | - | n° 6 | | MAN | | R452A | 1548x615x950 | 79 | Standard | - | 1 |

Voltaggio di serie - Standard voltage: 230v/1/50Hz • Classe climatica - Climatic class: MAX = (30°C - % U.R. 55)



Espositori e conservatori per gelato / Display cases and freezers for ice cream / Comptoir de présentoir et conservateur à glace / Aussteller und Gefriertruhen für Eis / Expositores y conservadores para helado

FIVSC 400

Colori standard
Standard colors
COD. 09



Termometro meccanico esterno / External mechanical thermometer / Thermomètre mécanique externe / Externe Mechanischer Thermometer / Exteriores termómetro mecánico

Esterno in lamiera verniciata bianco / Exterior in white painted plate / Extérieur en tôle verni en blanc / Aussenseite aus lackiertem weiß Blech / Exterior en chapa barnizada blanco

DI SERIE/STANDARD:
Ruote / Castors / Roues
Räder / Ruedas

| DIMENSIONI / SIZE / DIMENSIONS / MABE / MEDIDAS | A (mm) | B (mm) |
|---|--------|--------|
| FIVSC 200 | 720 | 600 |
| FIVSC 300 | 1009 | 890 |
| FIVSC 400 | 1298 | 1180 |
| FIVSC 500 | 1548 | 1430 |

FIVSC 200

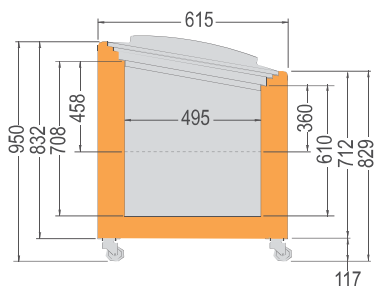
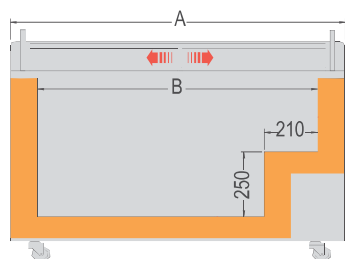

| | °C | Watt | Lt. | STANDARD | Max | DEFROST | H ₂ O | | mm. (LxPxH) | Kg. | | | |
|-----------|---------|------|-----|----------|------|---------|------------------|-------|--------------|-----|----------|---|---|
| FIVSC 200 | -12/-22 | 190 | 157 | - | n° 2 | MAN | MAN | R452A | 720x615x950 | 45 | Standard | - | 1 |
| FIVSC 300 | -12/-22 | 220 | 238 | - | n° 3 | MAN | MAN | R452A | 1009x615x950 | 56 | Standard | - | 1 |
| FIVSC 400 | -12/-22 | 300 | 325 | - | n° 5 | MAN | MAN | R452A | 1298x615x950 | 65 | Standard | - | 1 |
| FIVSC 500 | -12/-22 | 400 | 398 | - | n° 6 | MAN | MAN | R290 | 1548x615x950 | 79 | Standard | - | 1 |

Voltaggio di serie - Standard voltage: 230v/1/50Hz • Classe climatica - Climatic class: MAX = (30°C - % U.R. 55)

SPOT



SPOT 131 NT

ACCESSORI/ACCESSORIES:
Cesti / Baskets / Paniers / Koerbe / Cestas



DI SERIE/STANDARD:
Luce led / Led light / Lumière led / Led Licht / Luz led

DI SERIE/STANDARD:
Ruote / Castors / Roues
Räder / Ruedas

Termometro digitale esterno
External digital thermometer
Thermomètre numérique externe
Externe Digital-Thermometer
Termómetro digital externo

Esterno in acciaio verniciato bianco. Interno in alluminio gofrato
Outside made of white painted steel. Inside made in embossed aluminum / Extérieur en acier peint en blanc. L'intérieur fait en aluminium gaufré / Aussenteil aus weißlackierter Stahl. Innenteil aus geprägtem Aluminium / Externo de acero pintado blanco. Interno de aluminio gofrado

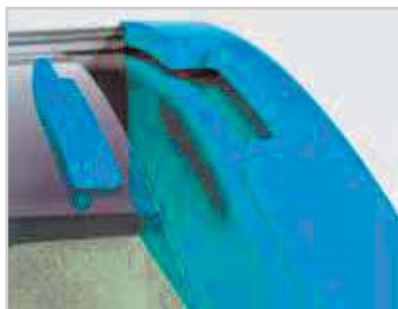

Il design del coperchio, l'isolamento migliorato e il telaio riscaldato garantiscono il minimo accumulo di ghiaccio.
The lid design, the improved insulation and the heated frame ensure minimum ice build-up.

ENERGY SAVE
SAVE UP TO 30% ENERGY
RISPARMIA FINO AL 30% DI ENERGIA

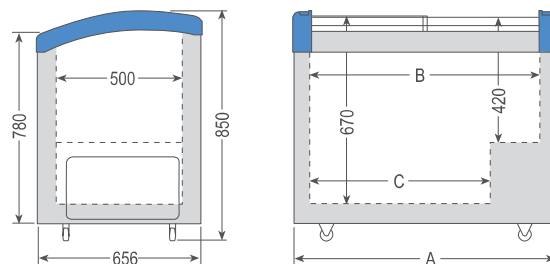

DIMENSIONI / SIZE / DIMENSIONS /
MABE / MEDIDAS

| | A (mm) | B (mm) | C (mm) |
|-------------|-----------|-----------|-----------|
| SPOT 106 NT | 1056 | 900 | 700 |
| SPOT 131 NT | 1306 | 1150 | 950 |
| SPOT 151 NT | 1506 | 1350 | 1150 |
| SPOT 171 NT | 1706 | 1550 | 1350 |

| | °C | Watt | Lt. | STANDARD | Max | DEFROST | H ₂ O | SNOW | LOCK | mm. (LxPxH) | Kg. | KEY | LED | WHEELS |
|-------------|---------|------|-----|----------|------|---------|------------------|-------|--------------|-------------|----------|--------------|-----|--------|
| SPOT 106 NT | -14/-23 | 166 | 193 | - | n° 4 | MAN | MAN | R600a | 1056x656x850 | 54 | Standard | LED Standard | 1 | |
| SPOT 131 NT | -14/-23 | 211 | 254 | - | n° 5 | MAN | MAN | R600a | 1306x656x850 | 62 | Standard | LED Standard | 1 | |
| SPOT 151 NT | -14/-23 | 290 | 302 | - | n° 6 | MAN | MAN | R290 | 1506x656x850 | 68 | Standard | LED Standard | 1 | |
| SPOT 171 NT | -14/-23 | 420 | 351 | - | n° 7 | MAN | MAN | R290 | 1706x656x850 | 73 | Standard | LED Standard | 1 | |

Voltaggio di serie - Standard voltage: 230v/1/50Hz • Classe climatica - Climatic class: MAX = (30°C - % U.R. 55)

IKG JUMBO



Espositori per gelati e surgelati / Ice cream and frozen food display units / Expositors pour glaces et surgelés / Aussteller für Eis und Tiefkühlkost / Expositores para helados y productos congelados

IKG JUMBO 200 AN

IKG JUMBO 250 AN



Comandi separati per ottenere diverse temperature nelle due celle / Separate controls to obtain different temperatures in two storages / Commandes séparâtes pour obtenir températures différentes dans les deux cellules / Separate Steuerungen um verschiedene Temperaturen in den zwei Zellen zu erzielen / Mandos separados para obtener temperaturas diferentes en las dos câmaras

IKG JUMBO 150 AN
IKG JUMBO 200 AN

IKG JUMBO 250 AN

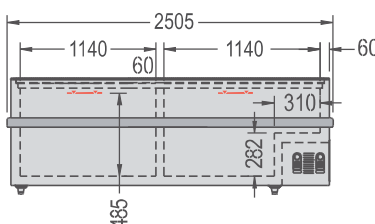
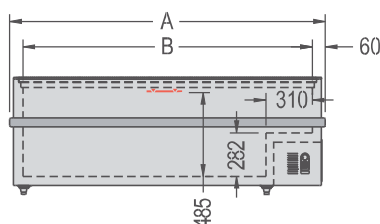
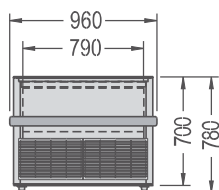

DIMENSIONI / SIZE / DIMENSIONS
MABE / MEDIDAS

| | A (mm) | B (mm) |
|------------------|-----------|-----------|
| IKG JUMBO 150 AN | 1550 | 1375 |
| IKG JUMBO 200 AN | 2050 | 1880 |

Esterno in lamiera zincata rivestita in PVC
Exterior made of galvanized sheet covered in PVC / Extérieur en tôle galvanisée recouverte de PVC / Außenseite in verzinktem Blech mit PVC überzogen / Exterior de chapa galvanizada revestida de PVC

Interno in lamiera rivestita in PVC atossico / Interior made of sheet covered in non toxic PVC / Intérieur en tôle recouvert de PVC atoxique / Innenseite aus Blech mit ungiftigem PVC überzogen / Interior de chapa revestida de PVC

atóxico
Congelamento veloce
Quick freezing / Congélation rapide / Schnelles Einfrieren / Congelamiento rápido

Scarico di liquidi
Discharge of liquids / Ecoulement de liquides / Flüssigkeitsentladung / Descarga de liquido

Centralina elettronica per il controllo della temperatura interna
Electronic control unit to check internal temperature / Central électronique pour le contrôle de la

température interne /
Elektronisches Steuergehäuse zur Kontrolle der Innentemperatur / Centralita electrónica para controlar temperatura interna

Forniti con 1 paio di coperchi scorrevoli in vetro termico
Provided with 1 pair of sliding covers made of thermic glass / Fournis avec 1 paire de couvercles coulissants en verre thermique / Mit 1 Paar länglichen Schiebedeckel aus Wärmeschutzglas geliefert / Suministrados con 1 par de tapas corredizas de cristal térmico

IKG JUMBO 150 AN
IKG JUMBO 200 AN

Forniti con 2 paia di coperchi scorrevoli trasversali in vetro termico / Provided with 2 pairs of transversal sliding covers made of thermic glass / Fournis avec 2 paires de couvercles coulissants transversaux en verre thermique / Mit 2 Paar queren Schiebedeckel aus Wärmeschutzglas geliefert / Suministrados con 2 pares de tapas corredizas transversales de cristal térmico



ACCESSORI / ACCESSORIES:
Separatori merci / Goods partitions / Intercalaires de marchandises / Warentrenner / Separadores de mercancías

| | °C | Watt | Lt. | STANDARD | Max | DEFROST | H ₂ O | | mm. (LxPxH) | Kg. | | | |
|------------------|---------|------|-----|----------|------|---------|------------------|---|--------------|-----|---|---|---|
| IKG JUMBO 150 AN | -15/-20 | 394 | 459 | n° 1 | n° 3 | ☄ | MAN | ☄ | 1550x960x780 | 81 | 2 | - | - |
| IKG JUMBO 200 AN | -15/-20 | 594 | 652 | n° 1 | n° 5 | ☄ | MAN | ☄ | 2050x960x780 | 105 | 2 | - | - |
| IKG JUMBO 250 AN | -15/-20 | 594 | 805 | n° 1 | n° 7 | ☄ | MAN | ☄ | 2505x960x780 | 125 | 2 | - | - |

Voltaggio di serie - Standard voltage: 230v/1/50Hz • Classe climatica - Climatic class: MAX = (30°C - % U.R. 55)

POLARIS



Espositori per gelati e surgelati / Ice cream and frozen food display units / Expositors pour glaces et surgelés / Aussteller für Eis und Tiefkühlkost / Expositores para helados y productos congelados

POLARIS 185

DI SERIE/STANDARD:

Sistema divisorio interno / Divider system
Système de diviseur / Divider System / Sistema divisorio interno

Colori standard
Standard colors

COD. 09



ACCESSORIO/ACCESSORY:

Batticarrello in basso / Bottom bumper
Pare-chocs bas / Stoßfängerunter / Parachoques inferior

Isolamento con 65 mm di spessore
Insulation thickness 65 mm.
Isolation avec 65 mm d'épaisseur
Isolierung durch eine Dicke von 65 mm.
Aislamiento de 65 mm de espesor

ACCESSORIO/ACCESSORY:

Kit piedi regolabili / Set adjustable feet /
Kit pieds réglables / Satz verstellbare füsse
h 100/150 mm.

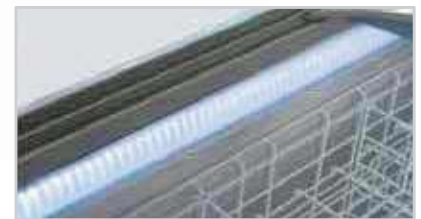

DI SERIE / STANDARD:
Luce LED / LED light
Lumière LED / Kunstlicht
Luz LED

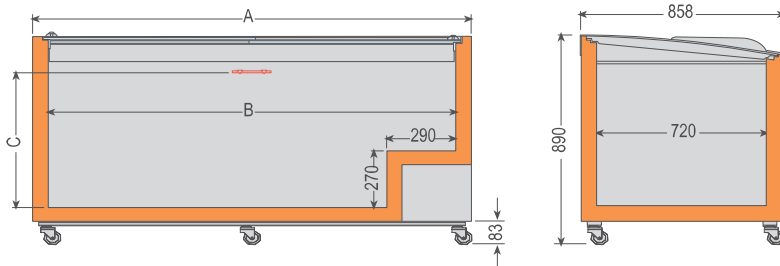

DIMENSIONI / SIZE
DIMENSIONS / MABE / MEDIDAS

| | A (mm) | B (mm) | C (mm) |
|----------------|-----------|-----------|-----------|
| POLARIS 185 PT | 1856 | 1720 | 550 |
| POLARIS 210 PT | 2106 | 1970 | 550 |
| POLARIS 250 PT | 2506 | 2370 | 550 |
| POLARIS 185 NT | 1856 | 1720 | 500 |
| POLARIS 210 NT | 2106 | 1970 | 500 |
| POLARIS 250 NT | 2506 | 2370 | 500 |

| | °C | Watt | Lt. | Sistema divisorio interno Internal divider system Système diviseur interne Interne Trennstegsystem Sistema divisorio interno | REFROST | H ₂ O | | mm. (LxPxH) | Kg. | | |
|----------------|---------|------|-----|--|---------|------------------|-------|--------------|-----|---|--------------|
| POLARIS 185 PT | 0/+10 | 490 | 550 | Standard | REFROST | MAN | R452A | 1856x858x890 | 144 | - | Led Standard |
| POLARIS 210 PT | 0/+10 | 660 | 641 | Standard | REFROST | MAN | R452A | 2106x858x890 | 175 | - | Led Standard |
| POLARIS 250 PT | 0/+10 | 700 | 786 | Standard | REFROST | MAN | R452A | 2506x858x890 | 200 | - | Led Standard |
| POLARIS 185 NT | -18/+23 | 500 | 563 | Standard | REFROST | MAN | R290 | 1856x858x890 | 122 | - | Led Standard |
| POLARIS 210 NT | -18/+23 | 560 | 653 | Standard | REFROST | MAN | R290 | 2106x858x890 | 152 | - | Led Standard |
| POLARIS 250 NT | -18/+23 | 590 | 797 | Standard | REFROST | MAN | R452A | 2506x858x890 | 172 | - | Led Standard |

Voltaggio di serie - Standard voltage: 230v/1/50Hz • Classe climatica - Climatic class: MAX = (25°C - % U.R. 60)

POLARIS MASTER



Esempio di composizione a isola:
POLARIS PT e NT con modulo di chiusura POLARIS MASTER
Example of island's composition:
POLARIS PT and NT with termination module POLARIS MASTER

POSSIBILITÀ DI INSTALLAZIONE / POSSIBILITY OF INSTALLATION:

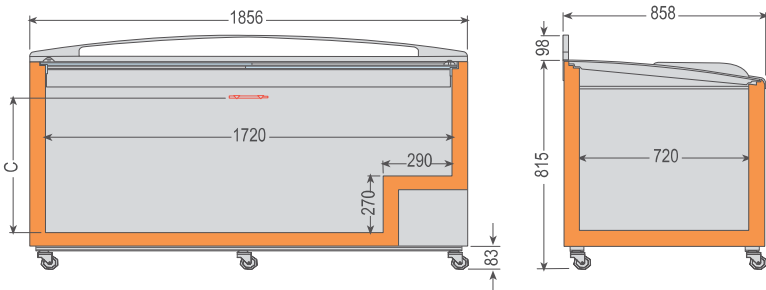
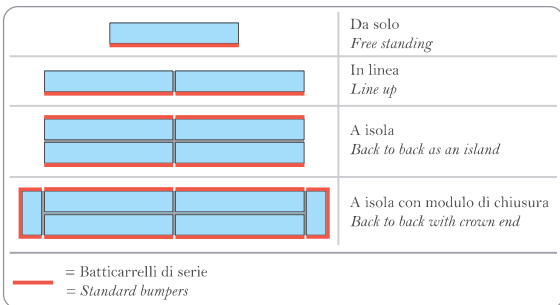

DIMENSIONI / SIZE
DIMENSIONS / MABE / MEDIDAS

| | C (mm) |
|-------------------|-----------|
| POLARIS MASTER PT | 475 |
| POLARIS MASTER NT | 425 |



DISPONIBILE SU RICHIESTA/
AVAILABLE ON REQUEST:

POLARIS COMBI
POLARIS MASTER COMBI









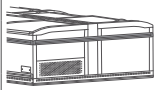

| | °C | Watt | Lt. | Sistema divisorio interno Internal divider system Système diviseur interne Interne Trennstegsystem Sistema divisorio interno | DEFROST | H ₂ O | | mm. (LxPxH) | Kg. | | |
|-------------------|---------|------|-----|--|---------|------------------|-------|--------------|-----|---|--------------|
| POLARIS MASTER PT | 0/+10 | 580 | 468 | Standard | MAN | | R452A | 1856x858x913 | 132 | - | Led Standard |
| POLARIS MASTER NT | -18/-23 | 450 | 470 | Standard | MAN | | R452A | 1856x858x913 | 111 | - | Led Standard |

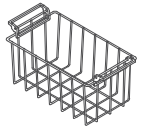
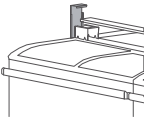
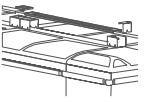
Voltaggio di serie - Standard voltage: 230v/1/50Hz • Classe climatica - Climatic class: MAX = (25°C - % U.R. 60)

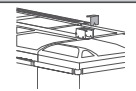
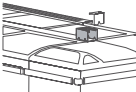
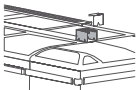

| MOD. |  LxPxH mm | Kg |  container n°(20') | |  colore colour color | |
|-------------------|--|-----|---|----------------------|--|--|
| | | | container n°(20') | container n°(40') | | |
| POS | 670x540x1100 | 59 | 64 | 136 | COD.09 | |
| POS 2 | 690x500x1350 | 41 | 32 | 68 | COD.30 | |
| AB 108 | 580x620x880 | 33 | 54 | 114 | COD.09 | |
| AB 200 | 760x710x960 | 44 | 42 | 90 | COD.09 | |
| AB 240 | 900x710x960 | 49 | 36 | 78 | COD.09 | |
| AB 300 | 1070x710x960 | 55 | 30 | 66 | COD.09 | |
| AB 350 | 1170x710x960 | 64 | 30 | 60 | COD.09 | |
| AB 396 | 1300x710x890 | 60 | 24 | 54 | COD.09 | |
| AB 425 | 1410x710x960 | 64 | 24 | 48 | COD.09 | |
| AB 506 | 1585x710x880 | 63 | 18 | 42 | COD.09 | |
| AB 530 | 1560x750x1000 | 71 | 20 | 44 | COD.09 | |
| AB 610 | 1760x760x975 | 83 | 18 | 38 | COD.09 | |
| AB 710 | 1850x790x980 | 89 | 14 | 30 | COD.09 | |
| AB 780 | 1910x825x1140 | 112 | 12 | 24 | COD.09 | |
| ABX 396 | 1300x710x890 | 60 | 24 | 54 | | |
| ABX 506 | 1585x710x880 | 68 | 18 | 42 | | |
| ABX 530 | 1560x750x1000 | 71 | 20 | 44 | | |
| ABX 610 | 1760x760x975 | 78 | 18 | 38 | | |
| ABX 710 | 1850x790x980 | 89 | 14 | 30 | | |
| ABX 920 | 2300x890x1000 | 147 | 8 | 20 | | |
| SB 200 | 960x700x960 | 58 | 36 | 72 | COD.09 | |
| SB 300 | 1300x700x960 | 68 | 24 | 54 | COD.09 | |
| SB 400 | 1600x700x960 | 77 | 18 | 42 | COD.09 | |
| SE 255 | 1300x700x850 | 67 | 24 | 54 | COD.09 | |
| SE 325 | 1600x700x850 | 75 | 18 | 42 | COD.09 | |
| RABI 300 | 1100x750x1005 | 67 | 30 | 60 | COD.09 | |
| RABI 400 | 1400x750x950 | 73 | 24 | 48 | COD.09 | |
| RABI 500 | 1640x750x1005 | 94 | 18 | 42 | COD.09 | |
| FKG 530 | 1545x760x940 | 71 | 18 | 42 | COD.09 | |
| FKG 610 | 1760x760x940 | 82 | 18 | 36 | COD.09 | |
| FKGR 273 | 960x700x960 | 65 | 36 | 72 | COD.09 | |
| FKGR 403 | 1300x700x960 | 78 | 24 | 54 | COD.09 | |
| FVS 200 | 740x680x920 | 58 | 42 | 96 | COD.09 | |
| FVS 300 | 1100x750x950 | 70 | 30 | 60 | COD.09 | |
| FVS 400 | 1370x745x945 | 80 | 24 | 48 | COD.09 | |
| FVS 500 | 1640x750x950 | 101 | 18 | 42 | COD.09 | |
| FVS 700 | 2140x810x950 | 125 | 14 | 28 | COD.09 | |
| FIVS 200 | 740x680x980 | 56 | 42 | 96 | COD.09 | |
| FIVS 300 | 1040x680x980 | 70 | 30 | 66 | COD.09 | |
| FIVS 400 | 1330x680x980 | 81 | 24 | 54 | COD.09 | |
| FIVS 500 | 1585x680x980 | 96 | 18 | 42 | COD.09 | |
| FIVSC 200 | 740x680x980 | 57 | 42 | 96 | COD.09 | |
| FIVSC 300 | 1040x680x980 | 70 | 30 | 66 | COD.09 | |
| FIVSC 400 | 1330x680x980 | 81 | 24 | 54 | COD.09 | |
| FIVSC 500 | 1585x680x980 | 96 | 18 | 42 | COD.09 | |
| SPOT 106 NT | 1100x760x880 | 58 | 30 | 60 | | |
| SPOT 131 NT | 1350x760x880 | 66 | 24 | 48 | | |
| SPOT 151 NT | 1550x760x880 | 73 | 18 | 42 | | |
| SPOT 171 NT | 1760x760x880 | 79 | 18 | 36 | | |
| IKG JUMBO 150 AN | 1640x1030x840 | 96 | 12 | 28 | COD.09 | |
| IKG JUMBO 200 AN | 2140x1030x840 | 120 | 8 | 20 | COD.09 | |
| IKG JUMBO 250 AN | 2590x1030x840 | 143 | 8 | 16 | COD.09 | |
| POLARIS 185 PT | 1920x920x1000 | 160 | 12 | 24 | COD.09 | |
| POLARIS 210 PT | 2170x920x1000 | 193 | 8 | 20 | COD.09 | |
| POLARIS 250 PT | 2570x920x1000 | 219 | 8 | 16 | COD.09 | |
| POLARIS 185 NT | 1920x920x1000 | 138 | 12 | 24 | COD.09 | |
| POLARIS 210 NT | 2170x920x1000 | 170 | 8 | 20 | COD.09 | |
| POLARIS 250 NT | 2570x920x1000 | 191 | 8 | 16 | COD.09 | |
| POLARIS MASTER PT | 1920x920x1000 | 147 | 12 | 24 | COD.09 | |
| POLARIS MASTER NT | 1920x920x1000 | 126 | 12 | 24 | COD.09 | |

NOTE

| Accessori - Accessories - Accessoires - Zuberhör - Accesorios | | MOD. | Codice |
|--|--|------------------|---------|
|  | Batticarrello superiore unione Polaris / Bumper upper, union Polaris / Pare-chocs supérieure Union Polaris / Bumper oberen Gewerkschaft Polaris / Parachoques superior Polaris union | POLARIS 185 PT | ACP1661 |
| | | POLARIS 210 PT | ACP1661 |
| | | POLARIS 250 PT | ACP1661 |
| | | POLARIS 185 NT | ACP1661 |
| | | POLARIS 210 NT | ACP1661 |
|  | Castelli in filo grande / Big divisor baskets / Paniers en fil grand / Körbe mit grosser Leitung / Cestas divisorio grande | IKG JUMBO 150 AN | C300301 |
| | | IKG JUMBO 200 AN | C300301 |
| | | IKG JUMBO 250 AN | C300301 |
|  | Cesto / Basket / Panier / Korb / Cestas | AB 108 | ACC0048 |
| | | AB 200 | 8747101 |
| | | AB 240 | 8747101 |
| | | AB 300 | 8747101 |
| | | AB 350 | 8747101 |
| | | AB 396 | 8747101 |
| | | AB 425 | 8747101 |
| | | AB 506 | 8747101 |
| | | AB 530 | A960301 |
| | | AB 610 | A960301 |
| | | AB 710 | A830301 |
| | | AB 780 | N450301 |
| | | ABX 396 | 8747101 |
| | | ABX 506 | 8747101 |
| | | ABX 530 | A960301 |
| | | ABX 610 | A960301 |
| | | ABX 710 | A830301 |
| | | ABX 920 | Y350301 |
| | | FIVS 200 | J177102 |
| | | FIVS 300 | J177102 |
| | | FIVS 400 | J177102 |
| | | FIVS 500 | J177102 |
| | | FIVSC 200 | J177102 |
| | | FIVSC 300 | J177102 |
| | | FIVSC 400 | J177102 |
| | | FIVSC 500 | J177102 |
| | | FKG 530 | A820302 |
| | | FKG 610 | A820302 |
| | | FKGR 273 | 8747101 |
| | | FKGR 403 | 8747101 |
| | | FVS 200 | J177101 |
| | | FVS 300 | J177101 |
| | | FVS 400 | J177101 |
| | | FVS 500 | J177101 |
| | | FVS 700 | J177101 |
| SB 200 | 6420301 | | |
| SB 300 | 6420301 | | |
| SB 400 | 6420301 | | |
| SE 255 | 6440301 | | |
| SE 325 | 6440301 | | |
| SPOT 106 NT | T190301 | | |
| SPOT 131 NT | T190301 | | |
| SPOT 151 NT | T190301 | | |
| SPOT 171 NT | T190301 | | |
|  | Copertura parete laterale / Cover, side wall / Couvrir, la paroi latérale / Cover, Seitenwand / Tapa de la pared lateral | POLARIS 185 PT | ACP1660 |
| | | POLARIS 210 PT | ACP1660 |
| | | POLARIS 250 PT | ACP1660 |
| | | POLARIS 185 NT | ACP1660 |
| | | POLARIS 210 NT | ACP1660 |
|  | Copertura superiore / Top cover / Le capot supérieur / Obere Abdeckung / Tapa superior | POLARIS 185 PT | ACP1662 |
| | | POLARIS 185 NT | ACP1662 |
| | | POLARIS 210 PT | ACP1663 |
| | | POLARIS 210 NT | ACP1663 |
| | | POLARIS 250 PT | ACP1664 |
|  | Divisorio per cestello / Basket divider / Diviseur au panier / Trennung für Körbe / Divisorio de cesta | POLARIS 250 NT | ACP1664 |
| | | SPOT 106 NT | T190302 |
| | | SPOT 131 NT | T190302 |
| | | SPOT 151 NT | T190302 |
| | | SPOT 171 NT | T190302 |

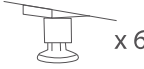
| Accessori - Accessories - Accessoires - Zuberhör - Accesorios | | MOD. |  Codice |
|---|---|-------------------|---|
|  | Elemento collegamento Polaris Master / Connection element for Polaris Master / Élément de raccordement pour Polaris Master / Verbindungselement für Polaris Master / Conexión de los elementos de Polaris Master | POLARIS MASTER PT | ACP1665 |
| | | POLARIS MASTER NT | ACP1665 |
|  | Elemento collegamento Profilo "U" / Connection element for U-Profile / L'élément de connexion pour U-Profil / Verbindungselement für U-Profil / Conexión de los elementos de U-perfil | POLARIS 185 PT | ACP1658 |
| | | POLARIS 210 PT | ACP1658 |
| | | POLARIS 250 PT | ACP1658 |
| | | POLARIS 185 NT | ACP1658 |
| | | POLARIS 210 NT | ACP1658 |
| | | POLARIS 250 NT | ACP1658 |
|  | Profilo "U" / U-Profile / U-Profil / U-Profil / U-perfil | POLARIS 185 PT | ACP1659 |
| | | POLARIS 210 PT | ACP1659 |
| | | POLARIS 250 PT | ACP1659 |
| | | POLARIS 185 NT | ACP1659 |
| | | POLARIS 210 NT | ACP1659 |
| | | POLARIS 250 NT | ACP1659 |
|  | Separatori alti per merci (esclude i cesti) / High goods partitions (not baskets) / Intercalaires de marchandises, haut (pas paniers) / Warentrenner Hoch (nicht Körbe) / Altas separadores de mercancías (no cestas) | IKG JUMBO 150 AN | C3005/1 |
| | | IKG JUMBO 200 AN | C3005/1 |
| | | IKG JUMBO 250 AN | C3005/1 |
|  | Separatori bassi per merci / Low goods partitions / Séparateurs marchandises à faible / Warentrenner basse / Bajos separadores de mercancías | IKG JUMBO 150 AN | C3005/2 |
| | | IKG JUMBO 200 AN | C3005/2 |
| | | IKG JUMBO 250 AN | C3005/2 |
|  | Sistema divisorio / Divider system / Système de diviseur / Divider System / Sistema divisorio | POS | A340801 |

| Optional - Optionnel - Extra - Extras | | MOD. |
|---|---|-------------------|
|  | 115V/60Hz Non disponibile per questi modelli / 115V/60Hz Not available for these models / 115V/60Hz Non disponible pour ces modèles / 115V/60Hz Nicht verfügbar für dieses Modelle / 115V/60Hz No disponible para estos modelos | POS |
| | | AB 108 |
| | | AB 200 |
| | | AB 240 |
| | | AB 300 |
| | | AB 350 |
| | | AB 396 |
| | | AB 425 |
| | | AB 506 |
| | | ABX 396 |
| | | ABX 506 |
| | | FKG 530 |
| | | FKG 610 |
| | | FKGR 273 |
| | | FKGR 403 |
|  | Kit 6 piedi regolabili / Set of 6 adjustable feet / Kit 6 pieds réglables / Satz von 6 verstellbare füsse / Kit 6 patas ajustables | POLARIS 185 PT |
| | | POLARIS 210 PT |
| | | POLARIS 250 PT |
| | | POLARIS 185 NT |
| | | POLARIS 210 NT |
| | | POLARIS 250 NT |
| | | POLARIS MASTER PT |
| POLARIS MASTER NT | | |
| | | h max 150 mm |

| Optional - Optionnel - Extra - Extras | | MOD. |
|---|---|--|
|  | Supplemento per inversione porta / Supplement for door inversion / Supplément pour inversion de porte / Zuschlag für Türumkehrung / Suplemento para inversión de puertas | Per informazioni vi preghiamo di contattare il nostro ufficio commerciale / For information, please contact our export department / Pour informations, veuillez contacter notre service commercial / Für Informationen kontaktieren Sie bitte unsere Verkaufsabteilung / Si necesita información adicional, no dude en ponerse en contacto con nuestro departamento de venta |
|  | Supplemento per presa elettrica diversa dalla standard / Supplement for electric socket different than the standard / Supplément pour prise électrique différent de la norme / Aufpreis für Steckdose abweichend vom Standard / Suplemento para toma de corriente diferente al estándar | |

CLIPPER SA



CLIPPER 102 SA SG

DI SERIE/STANDARD:
Staffe da muro
Standard: wall hooks
 De serie: supports mural
Standard: wand Halterungen
 Standard: soportes de pared

OPTIONAL:
Tubo LED rosa speciale per macellerie
Special pink LED tube for butcher shops

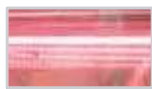

SU RICHIESTA/ON REQUEST:
Gruppo motore a distanza / *Remote engine compressor set* / *Groupe motocompresseur a distance*
 / *Kompressorfernaggregat* / *Grupo motocompresor remoto*

Di serie con gas R452A
 Standard with gas R452A

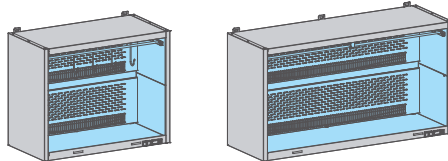
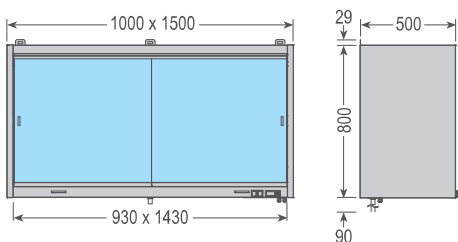

Espositori da appoggio e sospesi
Lean and suspended display case
Meuble refrigeré d'appui et suspendu
Stützhangeregale und Hängeelement - Kühlung
Expositor para apoyo y suspendido

DI SERIE/STANDARD:
CLIPPER 102:
 N°6 ganci
 N°6 hooks

CLIPPER 152:
 N°10 ganci
 N°10 hooks

DI SERIE/STANDARD:
Porte scorrevoli
Sliding doors
Portes coulissantes
Schiebetüre
Puertas corredizas

Quadro elettronico completo di termostato
Electronic control unit supplied with thermostat
Tableau électronique complet de thermostat
Elektronisches Schaltbrett mit Thermostat
Centralita electrónica provista de termostato

CLIPPER 102 - 152 SA

Due evaporatori statici completi di griglia di protezione in acciaio inox
Two static evaporators supplied with stainless steel shield grid
 Deux évaporateurs statiques munis de clayettes de protection en acier inoxydable
 Zwei statische Verdampfer mit Schutzgittern aus rostfreiem Stahl
 n. 2 evaporadores estaticos equipados con rejilla de protección de acero inoxidable

Isolamento in polistirene espanso senza C.F.C.
C.F.C. - free polystyrene foam insulation
 Isolation fondée sur des mousses écologiques à base de polystyrène sans C.F.C.
 Schaumisolierung aus Polystyrol ohne C.F.C.
 Aislamiento an poliestireno celular - sin C.F.C.

Costruzione in acciaio inox AISI 304
AISI 304 stainless steel construction
 Construction en acier inox AISI 304
 Gehäuse aus rostfreiem AISI 304
 Construcción en acero inox AISI 304

Colori standard
 Standard colors



| | °C | Watt Potenza frigorifera Refrigeration power (-10°C) | Carico MAX per barra MAX load for bar | DEFROST | H ₂ O | | | mm. (LxPxH) | Kg. | | | |
|------------------------------|-------|---|--|---------|------------------|--|-------|--------------|-----|---|--------------|---|
| NEW CLIPPER 102 SA SG | +4/+8 | 380 | 30 Kg | | MAN | | R452A | 1000x500x800 | 68 | - | LED Standard | - |
| NEW CLIPPER 152 SA SG | +4/+8 | 721 | 30 Kg | | MAN | | R452A | 1500x500x800 | 101 | - | LED Standard | - |

Voltaggio di serie - Standard voltage: 230v/1/50Hz • Classe climatica - Climatic class: MAX = (25°C - % U.R. 60)

CLIPPER



CLIPPER 102 SG

SU RICHIESTA/ON REQUEST:
Gruppo motore a distanza / Remote engine compressor set / Groupe motocompresseur a distance / Kompressorfernaggregat / Grupo motocompresor remoto

DI SERIE / STANDARD:
Tenda notte / Night blind
Rideau pour la nuit / Nachtrollo
Cortina autoenrolladora para la noche

Espositori da appoggio e sospesi
Lean and suspended display case
Meuble réfrigéré d'appui et suspendu
Stützhängeregale und Hängeelement - Kühlung
Expositor para apoyo y suspendido



Ripiani illuminati
Lighting over the shelves
Rayons éclairés
Beleuchtete Konsolen
Alumbrado en los anaqueles

Peso max per ripiano: 10 KG
Max weight per shelf: 10 KG

OPTIONAL:
Tubo LED rosa speciale per macellerie
Special pink LED tube for butcher shops



Quadro elettronico completo di termostato
Electronic control unit supplied with thermostat
Tableau électronique complet de thermostat
Elektronisches Schaltbrett mit Thermostat
Centralita electrónica provista de termostato

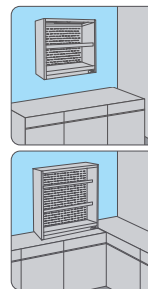

Colori standard
Standard colors



OPTIONAL:
Porte scorrevoli
Sliding doors
Portes coulissantes
Schiebetüre
Puertas corredizas

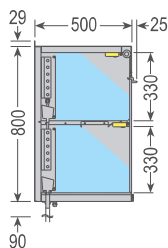
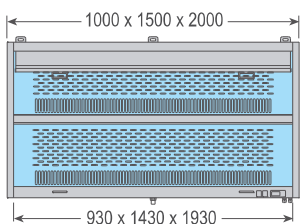

CLIPPER 102 - 152 - 202

Ripiano intermedio fisso
Fixed intermediate shelf
Rayon intermédiaire fixe
Feste Zwischenkonsole aus rostfreiem Stahl
Anaqueel intermedio fijo

Due evaporatori statici completi di griglia di protezione in acciaio inox
Two static evaporators supplied with stainless steel shield grid
Deux évaporateurs statiques munis de clayettes de protection en acier inoxydable
Zwei statische Verdampfer mit Schutzgittern aus rostfreiem Stahl
n. 2 evaporadores estaticos equipados con rejilla de proteccion de acero inoxidable

Costruzione in acciaio inox AISI 304
AISI 304 stainless steel construction
Construction en acier inox AISI 304
Gehäuse aus rostfreiem AISI 304
Construcción en acero inox AISI 304

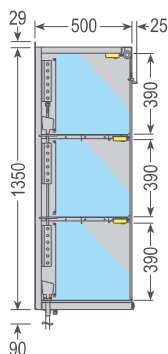
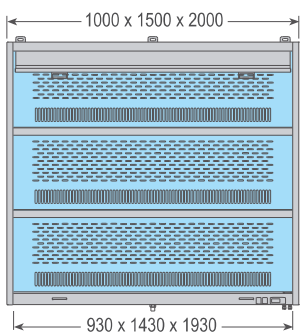

CLIPPER 103 - 153 - 203

Due ripiani intermedi fissi
Two fixed intermediate shelves
Deux rayons intermédiaires fixes
Zwei feste Zwischenkonsolen aus rostfreiem Stahl
Dos anaqueles intermedios fijos

Tre evaporatori statici completi di griglia di protezione in acciaio inox
Three static evaporators supplied with stainless steel shield grid
Trois évaporateurs statiques munis de clayettes de protection en acier inoxydable
Drei statische Verdampfer mit Schutzgittern aus rostfreiem Stahl
n. 3 evaporadores estaticos equipados con rejilla de proteccion de acero inoxidable

Isolamento in polistirene espanso senza C.F.C.
C.F.C. - free polystyrene foam insulation
Isolation fondée sur des mousses écologiques à base de polystyrène sans CFC
Schaumisolierung aus Polystyrol ohne C.F.C.
Aislamiento an poliestireno celular - sin C.F.C.

DI SERIE / STANDARD:
Staffe da muro
Standard: wall hooks
De serie: supports mural
Standard: wand Halterungen
Standard: soportes de pared

| | °C | Watt Potenza frigorifera Refrigeration power (-10°C) | DEFROST | H ₂ O | | | mm. (LxPxH) | Kg. | | | |
|----------------|-------|--|---------|------------------|--|--|---------------|-----|---|--------------|---|
| CLIPPER 102 SG | +4/+8 | 380 | | MAN | | | 1000x500x800 | 70 | - | LED Standard | - |
| CLIPPER 152 SG | +4/+8 | 721 | | MAN | | | 1500x500x800 | 105 | - | LED Standard | - |
| CLIPPER 202 SG | +4/+8 | 934 | | MAN | | | 2000x500x800 | 140 | - | LED Standard | - |
| CLIPPER 103 SG | +4/+8 | 721 | | MAN | | | 1000x500x1350 | 110 | - | LED Standard | - |
| CLIPPER 153 SG | +4/+8 | 934 | | MAN | | | 1500x500x1350 | 165 | - | LED Standard | - |
| CLIPPER 203 SG | +4/+8 | 1156 | | MAN | | | 2000x500x1350 | 220 | - | LED Standard | - |

Voltaggio di serie - Standard voltage: 230v/1/50Hz • Classe climatica - Climatic class: MAX = (25°C - % U.R. 60)

BABY



BABY 120

DI SERIE / STANDARD:
Tenda notte
 Night curtain / Rideau pour la nuit
 Nachtvorhang / Cortina para la noche

Centralina elettronica / Electronic control unit /
 Central électronique
 Elektronisches Steuergehäuse / Centralita electrónica



N° 4 ripiani spostabili e inclinabili, completi di porta prezzi in PVC
 N° 4 shelves, moveable and reclining, complete with PVC price holders
 N° 4 étagères réglables et inclinables, équipées de porte-prix en PVC
 N° 4 Ablagen, verstellbar und kippar, komplett mit Tür aus PVC
 N° 4 estantes ajustables e inclinables, incluyen portaprecios en PVC

LED laterali di serie
 Sides standard LED

Vasca in lamiera d'acciaio INOX
 Basin made of STAINLESS STEEL
 Bac en tôle d'acier INOX
 Becken aus NIROSTA
 Cuba: de chapa de acevo INOX

BABY 60



OPTIONAL:
Porte scorrevoli / Sliding doors
 Portes coulissantes / Schiebetüre
 Puertas corredizas



Interno ed esterno a vista: bianco
 Interior and exterior on sight: white
 Intérieur et extérieur visible : blanche
 Innen und außen sichtbar: weiß
 Interior y exterior a vista: blanco

OPTIONAL:
ESTERNO/EXTERIOR RAL



P: 590 mm.

DI SERIE / STANDARD:
Tenda notte
Night curtain
Rideau pour la nuit
Nachtvorhang
Cortina para la noche

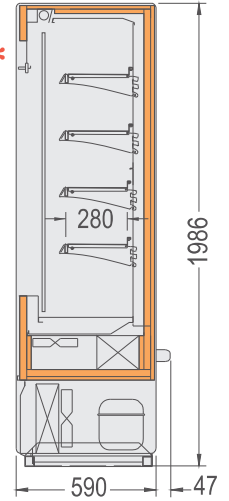

OPTIONAL:
INTERNO/INTERIOR BLACK & ESTERNO/EXTERIOR RAL



SG:

Disponibile in versione SG senza gruppo refrigerante
Available without refrigerating group, SG version
Disponible en version SG sans le group réfrigérant
Verfügbar in Version SG ohne gek. Gruppe
Disponible en version SG sin grupo refrigerador

Colori standard
Standard colors

Colori optional
Optional colors

COD. 17

RAL

| | °C | Watt | m ² Superficie espositiva Display surface | DEFROST | H ₂ O | | | mm. (LxPxH) | Porte/Doors OPTIONAL | Kg. | | | |
|----------|-------|------|--|---------|------------------|--|-------|---------------|--------------------------------|-----|---|---|--------------|
| BABY 60 | +4/+8 | 898 | 0,90 | | AUT | | R452A | 665x590x1986 | n° 2 | 115 | 1 | - | LED Standard |
| BABY 90 | +4/+8 | 898 | 1,35 | | AUT | | R452A | 965x590x1986 | n° 2 | 185 | 1 | - | LED Standard |
| BABY 120 | +4/+8 | 2200 | 1,80 | | AUT | | R452A | 1265x590x1986 | n° 2 | 255 | 1 | - | LED Standard |
| BABY 150 | +4/+8 | 2200 | 2,28 | | AUT | | R452A | 1605x590x1986 | n° 2 | 310 | 1 | - | LED Standard |

Voltaggio di serie - Standard voltage: 230v/1/50Hz • Classe climatica - Climatic class: MAX = (25°C - % U.R. 60)

BABY 90 INOX

P: 590 mm.

DI SERIE / STANDARD:
Tenda notte
Night curtain / Rideau pour la nuit
Nachvorhang / Cortina para la noche

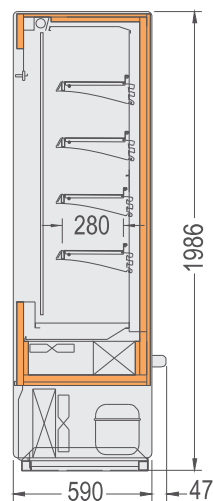

LED laterali di serie
Sides standard LED

N° 4 ripiani spostabili e inclinabili, completi di porta prezzi in PVC
N° 4 shelves, moveable and reclining, complete with PVC price holders
N° 4 étagères réglables et inclinables, équipées de porte-prix en PVC
N° 4 Ablagen, verstellbar und kippbar, komplett mit Tür aus PVC
N° 4 estantes ajustables e inclinables, incluyen portaprecios en PVC

Vasca in lamiera d'acciaio INOX
Basin made of STAINLESS STEEL
Bac en tôle d'acier INOX
Becken aus NIROSTA
Cuba: de chapa de acevo INOX

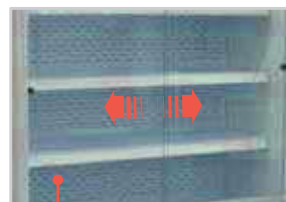

OPTIONAL:
Porte scorrevoli / Sliding doors
Portes coulissantes / Schiebetüre / Puertas corredizas

Centralina elettronica / Electronic control unit / Central électronique
Elektronisches Steuergehäuse / Centralita electrónica



Interno ed esterno a vista: inox
Interior and exterior on sight: stainless steel / Intérieur et extérieur visible: inox
Interne und Externe sichtbar: inox / Interior y exterior a vista: inox

Colori standard
Standard colors
COD. 08

SG:
Disponibile in versione SG senza gruppo refrigerante
Available without refrigerating group, SG version
Disponible en version SG sans le group réfrigérant
Verfügbar in Version SG ohne gek. Gruppe
Disponible en version SG sin grupo refrigerador

| | °C | Watt | m ² Superficie espositiva Display surface | DEFROST | H ₂ O | | mm. (LxPxH) | Porte/Doors OPTIONAL | Kg. | | | |
|---------------|-------|------|--|---------|------------------|--|---------------------|--------------------------------|-----|---|---|--------------|
| BABY 60 INOX | +4/+8 | 898 | 0,90 | | AUT | | R452A 665x590x1986 | n° 2 | 105 | 1 | - | LED Standard |
| BABY 90 INOX | +4/+8 | 898 | 1,35 | | AUT | | R452A 965x590x1986 | n° 2 | 175 | 1 | - | LED Standard |
| BABY 120 INOX | +4/+8 | 2200 | 1,80 | | AUT | | R452A 1265x590x1986 | n° 2 | 245 | 1 | - | LED Standard |
| BABY 150 INOX | +4/+8 | 2200 | 2,28 | | AUT | | R452A 1605x590x1986 | n° 2 | 310 | 1 | - | LED Standard |

Voltaggio di serie - Standard voltage: 230v/1/50Hz • Classe climatica - Climatic class: MAX = (25°C - % U.R. 60)

BABY PLUS 120

DI SERIE / STANDARD:
 Tenda notte
 Night curtain / Rideau pour la nuit
 Nachtvorhang / Cortina para la noche

P: 690 mm.

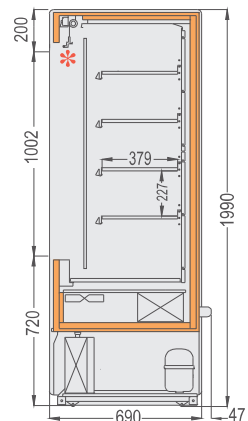

LED laterali di serie
 Sides standard LED



OPTIONAL:
 Porte scorrevoli / Sliding doors
 Portes coulissantes / Schiebefüre / Puertas corredizas

N° 4 ripiani spostabili e inclinabili, completi di porta prezzi in PVC / N° 4 shelves, moveable and reclining, complete with PVC price holders / N° 4 étagères réglables et inclinables, équipées de porte-prix en PVC / N° 4 Ablagen, verstellbar und kippar, komplett mit Tür aus PVC / N° 4 estantes ajustables e inclinables, incluyen portaprecios en PVC

Vasca in lamiera d'acciaio INOX
 Basin made of STAINLESS STEEL
 Bac en tôle d'acier INOX
 Becken aus NIROSTA
 Cuba: de chapa de acevo INOX

OPTIONAL:
 ESTERNO/EXTERIOR RAL



OPTIONAL:
 INTERNO/INTERIOR BLACK



Centralina elettronica / Electronic control unit / Central électronique
 Elektronisches Steuergehäuse / Centralita electrónica



Interno ed esterno a vista: bianco
 Interior and exterior on sight: white /
 Intérieur et extérieur visible : blanche
 Innen und außen sichtbar: weiß /
 Interior y exterior a vista: blanco

SG:

Disponibile in versione SG senza gruppo refrigerante
 Available without refrigerating group, SG version
 Disponible en version SG sans le group réfrigérant
 Verfügbar in Version SG ohne gek. Gruppe
 Disponible en version SG sin grupo refrigerador

Colori standard
 Standard colors



Colori optional
 Optional colors



| | °C | Watt | m ² Superficie espositiva Display surface | DEFROST | H ₂ O | | | mm. (LxPxH) | Porte/Doors OPTIONAL | Kg. | | | |
|---------------|-------|------|--|---------|------------------|--|-------|---------------|--------------------------------|-----|---|---|--------------|
| BABY PLUS 60 | +4/+8 | 898 | 1,20 | | AUT | | R452A | 665x690x1990 | n° 2 | 105 | 1 | - | LED Standard |
| BABY PLUS 90 | +4/+8 | 898 | 1,80 | | AUT | | R452A | 965x690x1990 | n° 2 | 185 | 1 | - | LED Standard |
| BABY PLUS 120 | +4/+8 | 2200 | 2,35 | | AUT | | R452A | 1265x690x1990 | n° 2 | 255 | 1 | - | LED Standard |

Voltaggio di serie - Standard voltage: 230v/1/50Hz • Classe climatica - Climatic class: MAX = (25°C - % U.R. 60)

BABY PLUS 120 INOX

DI SERIE / STANDARD:
Tenda notte
Night curtain / Rideau pour la nuit
Nachtvorhang / Cortina para la noche



P: 690 mm.

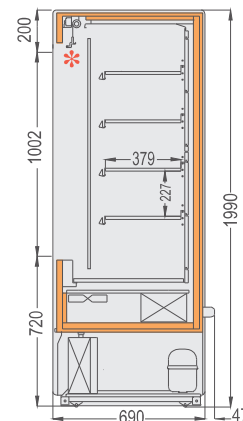

LED laterali di serie
Sides standard LED

N° 4 ripiani spostabili e inclinabili,
completi di porta prezzi in PVC / N° 4
shelves, moveable and reclining, complete
with PVC price holders / N° 4 étagères
réglables et inclinables, équipées de porte-
prix en PVC / N° 4 Ablagen, verstellbar
und kippar, komplett mit Tür aus PVC / N°
4 estantes ajustables e inclinables, incluyen
portaprecios en PVC



Vasca in lamiera d'acciaio INOX
Basin made of STAINLESS STEEL
Bac en tôle d'acier INOX
Becken aus NIROSTA
Cuba: de chapa de acevo INOX

OPTIONAL:
Porte scorrevoli / Sliding doors
Portes coulissantes / Schiebetüre / Puertas corredizas

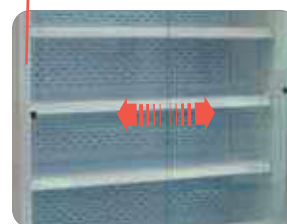

Centralina elettronica / Electronic control unit / Central électronique
Elektronisches Steuergelände / Centralita electrónica



Interno ed esterno a vista: inox
Interior and exterior on sight: stainless steel
Intérieur et extérieur visible: inox
Interne und Externe sichtbar: inox
Interior y exterior a vista: inox

SG:
Disponibile in versione SG senza gruppo refrigerante
Available without refrigerating group, SG version
Disponible en version SG sans le group réfrigérant
Verfügbar in Version SG ohne gek. Gruppe
Disponible en version SG sin grupo refrigerador

| | °C | Watt | m ² Superficie espositiva Display surface | DEFROST | H ₂ O | | mm. (LxPxH) | Porte/Doors OPTIONAL | Kg. | | | |
|--------------------|-------|------|--|---------|------------------|--|---------------|--------------------------------|-----|---|---|--------------|
| BABY PLUS 60 INOX | +4/+8 | 898 | 1,20 | | AUT | | 665x690x1990 | n° 2 | 105 | 1 | - | LED Standard |
| BABY PLUS 90 INOX | +4/+8 | 898 | 1,80 | | AUT | | 965x690x1990 | n° 2 | 185 | 1 | - | LED Standard |
| BABY PLUS 120 INOX | +4/+8 | 2200 | 2,35 | | AUT | | 1265x690x1990 | n° 2 | 255 | 1 | - | LED Standard |

Voltaggio di serie - Standard voltage: 230v/1/50Hz • Classe climatica - Climatic class: MAX = (25°C - % U.R. 60)

BABY PLUS 120 VL

DI SERIE / STANDARD:
Tenda notte
Night curtain / Rideau pour la nuit
Nachvorhang / Cortina para la noche

LED superiore di serie
Top standard LED



OPTIONAL:
INTERNO/INTERIOR BLACK



P: 690 mm.

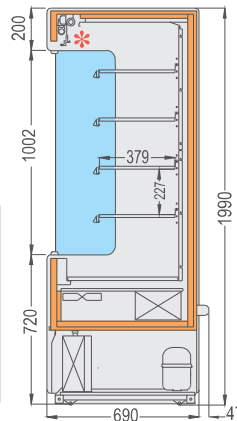

OPTIONAL:
ESTERNO/EXTERIOR RAL



DI SERIE / STANDARD:
Tenda notte
Night curtain / Rideau pour la nuit
Nachvorhang / Cortina para la noche

N° 4 ripiani spostabili e inclinabili, completi di porta prezzi in PVC / N° 4 shelves, moveable and reclining, complete with PVC price holders / N° 4 étagères réglables et inclinables, équipées de porte-prix en PVC / N° 4 Ablagen, verstellbar und kippbar, komplett mit Tür aus PVC / N° 4 estantes ajustables e inclinables, incluyen portaprecios en PVC

Vasca in lamiera d'acciaio INOX
Basin made of STAINLESS STEEL
Bac en tôle d'acier INOX
Becken aus NIROSTA
Cuba: de chapa de acevo INOX



Interno ed esterno a vista: bianco
Interior and exterior on sight: white /
Intérieur et extérieur visible : blanche
Innen und außen sichtbar: weiß /
Interior y exterior a vista: blanco

Centralina elettronica / Electronic control unit / Central électronique
Elektronisches Steuergehäuse / Centralita electrónica

Colori standard / Standard colors
Colori optional / Optional colors

COD. 17

RAL

SG:
Disponibile in versione SG senza gruppo refrigerante
Available without refrigerating group, SG version
Disponible en version SG sans le group réfrigérant
Verfügbar in Version SG ohne gek. Gruppe
Disponible en version SG sin grupo refrigerador

| | °C | Watt | m ² Superficie espositiva Display surface | REFROST | H ₂ O | | mm. (LxPxH) | Kg. | | | |
|------------------|-------|------|--|---------|------------------|--|---------------|-----|---|---|--------------|
| BABY PLUS 60 VL | +4/+8 | 898 | 1,20 | | AUT | | 665x690x1990 | 105 | 1 | - | LED Standard |
| BABY PLUS 90 VL | +4/+8 | 898 | 1,80 | | AUT | | 965x690x1990 | 185 | 1 | - | LED Standard |
| BABY PLUS 120 VL | +4/+8 | 2200 | 2,35 | | AUT | | 1265x690x1990 | 255 | 1 | - | LED Standard |

Voltaggio di serie - Standard voltage: 230v/1/50Hz • Classe climatica - Climatic class: MAX = (25°C - % U.R. 60)

BABY PLUS 120 INOX VL

DI SERIE / STANDARD:

Tenda notte
Night curtain / Rideau pour la nuit
Nächtvorhang / Cortina para la noche

LED superiore di serie
Top standard LED

P: 690 mm.

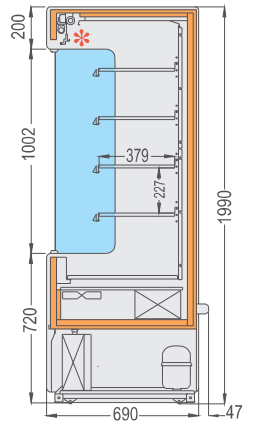

N° 4 ripiani spostabili e inclinabili, completi di porta prezzi in PVC / N° 4 shelves, moveable and reclining, complete with PVC price holders / N° 4 étagères réglables et inclinables, équipées de porte-prix en PVC / N° 4 Ablagen, verstellbar und kippar, komplett mit Tür aus PVC / N° 4 estantes ajustables e inclinables, incluyen portaprecios en PVC

Vasca in lamiera d'acciaio INOX
Basin made of STAINLESS STEEL
Bac en tôle d'acier INOX
Becken aus NIROSTA
Cuba: de chapa de acevo INOX

SG:
Disponibile in versione SG senza gruppo refrigerante
Available without refrigerating group, SG version
Disponibile en version SG sans le group réfrigérant
Verfügbar in Version SG ohne gek. Gruppe
Disponibile en version SG sin grupo refrigerador

Colori standard
Standard colors



Centralina elettronica / Electronic control unit / Central électronique
Elektronisches Steuergehäuse / Centralita electrónica





Interno ed esterno a vista: inox
Interior and exterior on sight: stainless steel / Intérieur et extérieur visible: inox
Interne und Externe sichtbar: inox / Interior y exterior a vista: inox

| | °C | Watt | m ² Superficie espositiva Display surface | DEFROST | H ₂ O | | mm. (LxPxH) | Kg. | | | |
|-----------------------|-------|------|--|---------|------------------|--|---------------|-----|---|---|--------------|
| BABY PLUS 60 INOX VL | +4/+8 | 898 | 1,20 | | AUT | | 665x690x1990 | 105 | 1 | - | LED Standard |
| BABY PLUS 90 INOX VL | +4/+8 | 898 | 1,80 | | AUT | | 965x690x1990 | 185 | 1 | - | LED Standard |
| BABY PLUS 120 INOX VL | +4/+8 | 2200 | 2,35 | | AUT | | 1265x690x1990 | 255 | 1 | - | LED Standard |



Voltaggio di serie - Standard voltage: 230v/1/50Hz • Classe climatica - Climatic class: MAX = (25°C - % U.R. 60)

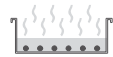
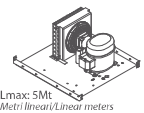

| MOD. | LxPxH mm | Kg |  | | colore colour color |
|-------------------|---------------|-----|---|----------------------|---------------------------|
| | | | container n°(20') | container n°(40') | |
| CLIPPER 102 SA SG | 1050x670x1350 | 100 | 15 | 33 | COD.08 |
| CLIPPER 152 SA SG | 1600x600x1350 | 145 | 18 | 42 | COD.08 |
| CLIPPER 102 SG | 1050x670x1350 | 100 | 15 | 33 | COD.08 |
| CLIPPER 152 SG | 1600x600x1350 | 145 | 18 | 42 | COD.08 |
| CLIPPER 202 SG | 2020x740x1230 | 158 | 6 | 15 | COD.08 |
| CLIPPER 103 SG | 1050x670x1720 | 140 | 15 | 30 | COD.08 |
| CLIPPER 153 SG | 1600x600x1450 | 205 | 9 | 21 | COD.08 |
| CLIPPER 203 SG | 2050x750x1820 | 270 | 6 | 15 | COD.08 |
| BABY 60 | 700x640x2080 | 125 | 24 | 51 | COD.17 |
| BABY 90 | 990x640x2080 | 200 | 15 | 36 | COD.17 |
| BABY 120 | 1290x640x2080 | 275 | 12 | 27 | COD.17 |
| BABY 150 | 1630x640x2080 | 335 | 9 | 21 | COD.17 |
| BABY 60 INOX | 700x640x2080 | 115 | 24 | 51 | COD.08 |
| BABY 90 INOX | 990x640x2080 | 190 | 15 | 36 | COD.08 |

| MOD. | LxPxH mm | Kg |  | | colore colour color |
|-----------------------|---------------|-----|---|----------------------|---------------------------|
| | | | container n°(20') | container n°(40') | |
| BABY 120 INOX | 1290x640x2080 | 265 | 12 | 27 | COD.08 |
| BABY 150 INOX | 1630x640x2080 | 325 | 9 | 21 | COD.08 |
| BABY PLUS 60 | 700x740x2080 | 115 | 24 | 51 | COD.17 |
| BABY PLUS 90 | 990x740x2080 | 200 | 15 | 36 | COD.17 |
| BABY PLUS 120 | 1290x740x2080 | 275 | 12 | 27 | COD.17 |
| BABY PLUS 60 INOX | 700x740x2080 | 115 | 24 | 51 | COD.08 |
| BABY PLUS 90 INOX | 990x740x2080 | 200 | 15 | 36 | COD.08 |
| BABY PLUS 120 INOX | 1290x740x2080 | 275 | 12 | 27 | COD.08 |
| BABY PLUS 60 VL | 700x740x2080 | 115 | 24 | 51 | COD.17 |
| BABY PLUS 90 VL | 990x740x2080 | 200 | 15 | 36 | COD.17 |
| BABY PLUS 120 VL | 1290x740x2080 | 275 | 12 | 27 | COD.17 |
| BABY PLUS 60 INOX VL | 700x740x2080 | 115 | 24 | 51 | COD.08 |
| BABY PLUS 90 INOX VL | 990x740x2080 | 200 | 15 | 36 | COD.08 |
| BABY PLUS 120 INOX VL | 1290x740x2080 | 275 | 12 | 27 | COD.08 |

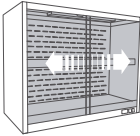
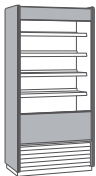
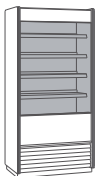
| Accessori - Accessories - Accessoires - Zuberhör - Accesorios | | MOD. |  Codice |
|--|---|--|---|
|  | Carter protezione tubi / Protection of pipes / Protection des tuyaux ou / Schutz von Rohren / Protección de los tubos | CLIPPER 102 SG CLIPPER 103 SG CLIPPER 152 SG CLIPPER 153 SG CLIPPER 202 SG CLIPPER 203 SG | G310305 G310305 G330304 G330304 G350304 G350304 |
|  | Kit evaporazione acqua di sbrinamento / Defrosting water evaporation kit / Kit d'évaporation de l'eau de dégivrage / Verdampfungskit Abtauenwasser / Kit evaporación de agua de descongelación | BABY SG TUTTI | W48022 |
|  Lmax: 5Mt Metri lineari/Linear meters | Gruppo motore a distanza predisposto a valvola / Remote engine compressor set for valve / Groupe motocompresseur a distance predispose a valve / Kompressorfernaggregat für das ventil-voreingestelltes / Grupo motocompresor remoto predispuerto de válvula | BABY 60 INOX SG BABY 60 SG BABY 90 INOX SG BABY 90 SG BABY 120 INOX SG BABY 120 SG BABY 150 INOX SG BABY 150 SG BABY 180 SG BABY PLUS 120 INOX SG BABY PLUS 120 SG BABY PLUS 60 INOX SG BABY PLUS 60 SG BABY PLUS 90 INOX SG BABY PLUS 90 SG CLIPPER 102 SA SG CLIPPER 152 SA SG CLIPPER 102 SG CLIPPER 103 SG CLIPPER 152 SG CLIPPER 153 SG CLIPPER 202 SG CLIPPER 203 SG | W19002MAT W19002MAT W19003MAT W19003MAT W19004MAT W19004MAT W19004MAT W19004MAT W19005MAT W19004MAT W19004MAT W19002MAT W19002MAT W19003MAT W19003MAT G3219/2MAT G3219/2MAT G3119/1MAT B6319/1MAT B6319/1MAT G3219/2MAT G3219/2MAT B6419/1MAT |

ACCESSORI BACINELLE E COPERCHI INOX: verificare capacità e composizione a catalogo. Pag. 569 / ACCESSORIES STAINLESS STEEL BASINS AND LIDS: please verify the capacity and composition in the catalogue. Page 569 / ACCESSOIRES BACS ET COUVERCLES EN INOX: vérifier la capacité et la composition dans le catalogue. Page 569 / ZUBEHÖR INOX SCHALEN UND DECKEL: überprüfen Sie Kapazität und Zusammensetzung im Katalog. Seite 569 / ACCESORIOS CUBETAS Y TAPAS INOX: ver capacidad y composición en el catálogo. Pag. 569

| Optional - Optionnel - Extra - Extras | | MOD. |
|--|--|---|
|  <p>Porte scorrevoli in vetro / Glass sliding doors / Portes coulissantes en vitre / Schiebetüren aus glas / Puertas corredizas en vidrio</p> | LxPxH - 305 x 6 x 1054 mm | CLIPPER 102 SG |
| | | CLIPPER 152 SG |
| | | CLIPPER 202 SG |
| | | CLIPPER 103 SG |
| | | CLIPPER 153 SG |
| | | CLIPPER 203 SG |
| | LxPxH - 455 x 6 x 1054 mm | BABY 60 |
| | | BABY 60 INOX |
| | | BABY PLUS 60 |
| | LxPxH - 605 x 6 x 1054 mm | BABY PLUS 60 INOX |
| | | BABY 90 |
| | | BABY 90 INOX |
| | LxPxH - 775 x 6 x 1054 mm | BABY PLUS 90 |
| | | BABY PLUS 90 INOX |
| | | BABY 120 |
| | LxPxH - 605 x 6 x 1054 mm | BABY 120 INOX |
| BABY PLUS 120 | | |
| BABY PLUS 120 INOX | | |
|  <p>Esterno colore RAL / Outside RAL colour / Extérieur RAL / Externe RAL-Farbe / Exterior de color RAL</p> | BABY 60 | |
| | BABY 90 | |
| | BABY 120 | |
| | BABY 150 | |
| | BABY PLUS 60 | |
| | BABY PLUS 90 | |
| | BABY PLUS 120 | |
| | BABY PLUS 60 VL | |
| | BABY PLUS 90 VL | |
| | BABY PLUS 120 VL | |
| | BABY 60 | |
| BABY 90 | | |
| BABY 120 | | |
| BABY 150 | | |
| BABY PLUS 60 | | |
| BABY PLUS 90 | | |
| BABY PLUS 120 | | |
| BABY PLUS 60 VL | | |
| BABY PLUS 90 VL | | |
| BABY PLUS 120 VL | | |
|  <p>Interno colore RAL / RAL colour inside / Intérieur RAL / Interne Ral Farbe / Interior de color RAL</p> | BABY 60 | |
| | BABY 90 | |
| | BABY 120 | |
| | BABY 150 | |
| | BABY PLUS 60 | |
| | BABY PLUS 90 | |
| | BABY PLUS 120 | |
| | BABY PLUS 60 VL | |
| | BABY PLUS 90 VL | |
| | BABY PLUS 120 VL | |
| |  <p>Valvola solenoide / Solenoid valve / Solenoidventil / Soupape solénoïdale / Válvula solenoide</p> | SU TUTTI I GRUPPI MOTORE / ON ALL ENGINE COMPRESSOR / SUR TOUT LES MOTOCOMPRESSEUR / ALLER KOMPRESSORFERNAGREGAT / EN TODOS LOS GRUPO MOTOCOMPRESOR |

| Optional - Optionnel - Extra - Extras | | MOD. |
|--|--|------|
|  <p>Supplemento per inversione porta / Supplement for door inversion / Supplément pour inversion de porte / Zuschlag für Türumkehrung / Suplemento para inversión de puertas</p> | Per informazioni vi preghiamo di contattare il nostro ufficio commerciale / For information, please contact our export department / Pour informations, veuillez contacter notre service commercial / Für Informationen kontaktieren Sie bitte unsere Verkaufsabteilung / Si necesita información adicional, no dude en ponerse en contacto con nuestro departamento de venta | |
|  <p>Supplemento per presa elettrica diversa dalla standard / Supplement for electric socket different than the standard / Supplément pour prise électrique différent de la norme / Aufpreis für Steckdose abweichend vom Standard / Suplemento para toma de corriente diferente al estándar</p> | | |

SPACE / SPACE PLUS



OPTIONAL

illuminazione LED sui ripiani
LED lighting for shelves / Eclairage LED dans les étagères /
LED-Beleuchtung an den Regalen / Iluminación LED en los estantes



ACCESSORIO/ACCESSORY

Barra di carico con ganci
Hanging bars and hooks / Bars et crochets de charge /
Ladestangen und haken / Barras de suspensión y ganchos



ACCESSORIO/ACCESSORY

Ruote
Castors / Roues / Wheels / Ruedas



DI SERIE/STANDARD

Tenda notte / Night curtain / Rideau pour la nuit
Nachtvorhang / Cortina para la noche



OPTIONAL

Spalle cieche di chiusura / Blind shoulder of closing / Épaules aveugle
de fermeture / Blinde Schulter des Schließens / Hombro ciegos laterales de cierre



OPTIONAL

Versione con porte battenti di chiusura in vetro / Version with hinged glass
closing doors / Version avec portes battantes de fermeture en verre / Version mit
Flügelüren aus Glas / Version con puertas batientes en vidrio



SPACE 131.1

P = 665

DI SERIE / STANDARD:
illuminazione LED superiore
 Higher LED lighting
 Éclairage LED supérieur
 Höhere LED-Beleuchtung
 Iluminación LED superior

DI SERIE / STANDARD:
Tenda notte
 Night curtain / Rideau pour la nuit
 Nachtvorhang / Cortina para la noche

DI SERIE / STANDARD:
Porta prezzi
 Price holder
 Porte-prix
 Preisausstellern
 Expositor para precios

Piedini regolabili
 Adjustable feet
 Pieds réglables
 Vestellbare Fusse
 Patas regulables

| Colori standard Standard colors | | Colori optional Optional colors | | | | |
|------------------------------------|---------|------------------------------------|----------|----------|----------|----------|
| | COD. 17 | | | | | |
| | | RAL 2002 | RAL 9006 | RAL 1037 | RAL 6018 | RAL 9005 |

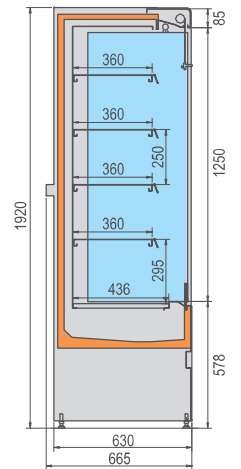

Interno ed esterno in acciaio verniciato bianco
 Interior and exterior in white painted steel
 Intérieur et extérieur en inox verni en blanche
 Interne und externe aus lackiertem Inox weiß
 Interior y exterior en acero pintado blanco

4 ripiani regolabili in altezza in acciaio verniciato
 4 adjustable shelves on height in painted steel
 4 étagères réglables en hauteur en acier peinte
 4 in hoehe verstellbare Auflagen, aus lackiertem Stahl
 4 estantes regulables en altura en acero pintado

OPTIONAL:
 Versione con porte battenti di chiusura in vetro / Version with hinged glass closing doors / Version avec portes battantes de fermeture en verre / Version mit Flügelüren aus Glas / Versión con puertas batientes en vidrio



OPTIONAL: RAL

| | °C | Watt Potenza elettrica Electric power | Watt Potenza frigorifera Refrigeration power (-10°C) | m² Superficie espositiva Display surface | | H ₂ O | | | mm. (LxPxH) | Porte/Doors OPTIONAL | Kg. | | | |
|-------------|-------|---|---|--|--|------------------|--|-------|---------------|--------------------------------|-----|---|---|--------------|
| SPACE 91.1 | +2/+4 | 1370 | 1750 | 1,03 | | AUT | | R452A | 866x665x1920 | - | 160 | 1 | - | Led Standard |
| SPACE 131.1 | +2/+4 | 1930 | 1910 | 1,60 | | AUT | | R452A | 1310x665x1920 | n° 2 | 210 | 1 | - | Led Standard |
| SPACE 151.1 | +2/+4 | 1930 | 1910 | 1,85 | | AUT | | R452A | 1510x665x1920 | n° 2 | 235 | 1 | - | Led Standard |
| SPACE 201.1 | +2/+4 | 2085 | 2425 | 2,40 | | AUT | | R452A | 1935x665x1920 | n° 3 | 300 | 1 | - | Led Standard |

Voltaggio di serie - Standard voltage: 230v/1/50Hz • Classe climatica - Climatic class: MAX = (25°C - % U.R. 60)

SPACE 131.1 INOX

P = 665

DI SERIE / STANDARD:
 Illuminazione LED superiore
 Higher LED lighting
 Éclairage LED supérieur
 Höhere LED-Beleuchtung
 Iluminación LED superior

DI SERIE / STANDARD:
 Tenda notte
 Night curtain / Rideau pour la nuit
 Nachtvorhang / Cortina para la noche

DI SERIE / STANDARD:
 Porta prezzi
 Price holder
 Porte-prix
 Preisausstellern
 Expositor para precios

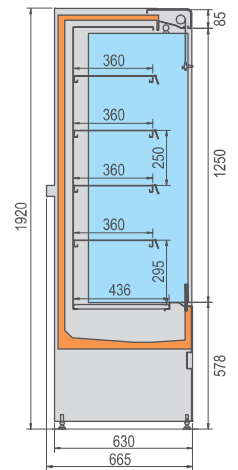

OPTIONAL:
 Spalle cieche di chiusura / Blind shoulder of closing /
 Épaules aveugle de fermeture / Blinde Schulter des Schließens /
 Hombros ciegos laterales de cierre



Piedini regolabili / Adjustable feet / Pieds réglables
 Vestellbare Fusse / Patas regulables

Interno ed esterno a vista: inox
 Interior and exterior on sight: stainless steel
 Intérieur et extérieur visible: inox
 Interne und Externe sichtbar: inox
 Interior y exterior a vista: acero inoxidable

4 ripiani regolabili in altezza in acciaio inox
 4 adjustable shelves on height in stainless steel
 4 étagères réglables en hauteur en acier inoxydable
 4 in hoehe verstellbare Auflagen, aus Edelstahl
 4 estantes regulables en altura en acero inoxidable

Colori standard
 Standard colors



OPTIONAL:
 Versione con porte battenti di chiusura in vetro / Version with hinged
 glass closing doors / Version avec portes battantes de fermeture en verre /
 Version mit Flügeltüren aus Glas / Versión con puertas batientes en vidrio



| | °C | Watt Potenza elettrica Electric power | Watt Potenza frigorifera Refrigeration power (-10°C) | m ² Superficie espositiva Display surface | DEFROST | H ₂ O | | mm. (LxPxH) | Porte/Doors OPTIONAL | Kg. | | | |
|------------------|-------|---|---|--|---------|------------------|--|---------------------|--------------------------------|-----|---|---|--------------|
| SPACE 91.1 INOX | +2/+4 | 1370 | 1750 | 1,03 | | AUT | | R452A 866x665x1920 | - | 160 | 1 | - | Led Standard |
| SPACE 131.1 INOX | +2/+4 | 1930 | 1910 | 1,60 | | AUT | | R452A 1310x665x1920 | n° 2 | 210 | 1 | - | Led Standard |
| SPACE 151.1 INOX | +2/+4 | 1930 | 1910 | 1,85 | | AUT | | R452A 1510x665x1920 | n° 2 | 235 | 1 | - | Led Standard |
| SPACE 201.1 INOX | +2/+4 | 2085 | 2425 | 2,40 | | AUT | | R452A 1935x665x1920 | n° 3 | 300 | 1 | - | Led Standard |

Voltaggio di serie - Standard voltage: 230v/1/50Hz • Classe climatica - Climatic class: MAX = (25°C - % U.R. 60)

SPACE PLUS 131.1

P = 855

DI SERIE / STANDARD:
Illuminazione LED superiore
 Higher LED lighting
 Éclairage LED supérieur
 Höhere LED-Beleuchtung
 Iluminación LED superior

DI SERIE / STANDARD:
Tenda notte
 Night curtain / Rideau pour la nuit
 Nachtvorhang / Cortina para la noche

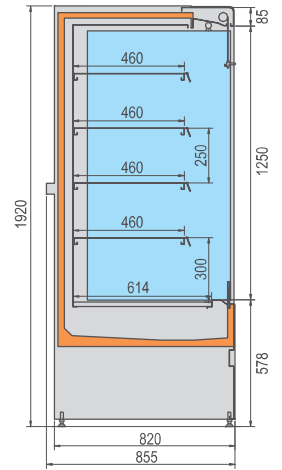

DI SERIE / STANDARD:
Porta prezzi
 Price holder
 Porte-prix
 Preisausstellen
 Expositor para precios

Interno ed esterno in acciaio verniciato bianco
 Interior and exterior in white painted steel
 Intérieur et extérieur en inox verni en blanche
 Interne und externe aus lackiertem Inox weiß
 Interior y exterior en acero pintado blanco

4 ripiani regolabili in altezza in acciaio verniciato
 4 adjustable shelves on height in epoxed painted steel
 4 étagères réglables en hauteur en acier peinte
 4 in hoehe verstellbare Auflagen, aus lackiertem Stahl
 4 estantes regulables en altura en acero pintado

OPTIONAL:
 Versione con porte battenti di chiusura in vetro / Version with hinged glass closing doors / Version avec portes battantes de fermeture en verre / Version mit Flügelüren aus Glas / Versión con puertas batientes en vidrio

Piedini regolabili
 Adjustable feet
 Pieds réglables
 Vestellbare Fusse
 Patas regulables



OPTIONAL: RAL

Colori standard
Standard colors

Colori optional
Optional colors



| | °C | Watt Potenza elettrica Electric power | Watt Potenza frigorifera Refrigeration power (-10°C) | m ² Superficie espositiva Display surface | DEFROST | H ₂ O | | mm. (LxPxH) | Porte/Doors OPTIONAL | Kg. | | | | |
|------------------|-------|---|---|--|---------|------------------|--|-------------|--------------------------------|------|-----|---|---|--------------|
| SPACE PLUS 91.1 | +2/+4 | 1400 | 2060 | 1,10 | | AUT | | R452A | 866x855x1920 | - | 185 | 1 | - | Led Standard |
| SPACE PLUS 131.1 | +2/+4 | 1520 | 2355 | 1,71 | | AUT | | R452A | 1310x855x1920 | n° 2 | 240 | 1 | - | Led Standard |
| SPACE PLUS 151.1 | +2/+4 | 1520 | 2355 | 1,98 | | AUT | | R452A | 1510x855x1920 | n° 2 | 260 | 1 | - | Led Standard |
| SPACE PLUS 201.1 | +2/+4 | 2300 | 2990 | 2,56 | | AUT | | R452A | 1935x855x1920 | n° 3 | 300 | 1 | - | Led Standard |
| SPACE PLUS 259.1 | +2/+4 | 3600 | 4710 | 3,42 | | AUT | | R452A | 2560x855x1920 | n° 4 | 380 | 2 | - | Led Standard |

Voltaggio di serie - Standard voltage: 230v/1/50Hz • Classe climatica - Climatic class: MAX = (25°C - % U.R. 60)

SPACE PLUS 131.1 INOX

P = 855



DI SERIE / STANDARD:
Tenda notte
Night curtain / Rideau pour la nuit
Nachtvorhang / Cortina para la noche

DI SERIE / STANDARD:
Illuminazione LED superiore
Higher LED lighting
Éclairage LED supérieur
Höhere LED-Beleuchtung
Iluminación LED superior

DI SERIE / STANDARD:
Porta prezzi
Price holder
Porte-prix
Preisausstellern
Expositor para precios

Piedini regolabili / Adjustable feet / Pieds réglables
Vestellbare Fusse / Patas regulables

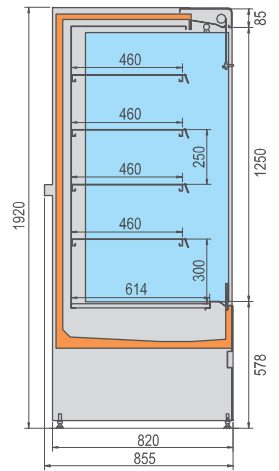

OPTIONAL:
Spalle cieche di chiusura / Blind shoulder of closing /
Épaules aveugle de fermeture / Blinde Schulter des
Schließens / Hombros ciegos laterales de cierre



Interno ed esterno a vista: inox
Interior and exterior on sight: stainless steel
Intérieur et extérieur visible: inox
Interne und Externe sichtbar: inox
Interior y exterior a vista: acero inoxidable

4 ripiani regolabili in altezza in acciaio inox
4 adjustable shelves on height in stainless steel
4 étagères réglables en hauteur en acier inoxydable
4 in hoehe verstellbare Auflagen, aus Edelstahl
4 estantes regulables en altura en acero inoxidable

Colori standard
Standard colors
COD. 08

OPTIONAL:
Versione con porte battenti di chiusura in vetro / Version with hinged
glass closing doors / Version avec portes battantes de fermeture en verre /
Version mit Flügeltüren aus Glas / Versión con puertas batientes en vidrio

| | °C | Watt Potenza elettrica Electric power | Watt Potenza frigorifera Refrigeration power (-10°C) | m ² Superficie espositiva Display surface | DEFROST | H ₂ O | | mm. (LxPxH) | Porte/Doors OPTIONAL | Kg. | | | |
|-----------------------|-------|---|---|--|---------|------------------|--|---------------------|--------------------------------|-----|---|---|--------------|
| SPACE PLUS 91.1 INOX | +2/+4 | 1400 | 2060 | 1,10 | | AUT | | R452A 866x855x1920 | - | 185 | 1 | - | Led Standard |
| SPACE PLUS 131.1 INOX | +2/+4 | 1520 | 2355 | 1,71 | | AUT | | R452A 1310x855x1920 | n° 2 | 240 | 1 | - | Led Standard |
| SPACE PLUS 151.1 INOX | +2/+4 | 1520 | 2355 | 1,98 | | AUT | | R452A 1510x855x1920 | n° 2 | 260 | 1 | - | Led Standard |
| SPACE PLUS 201.1 INOX | +2/+4 | 2300 | 2990 | 2,56 | | AUT | | R452A 1935x855x1920 | n° 3 | 300 | 1 | - | Led Standard |
| SPACE PLUS 259.1 INOX | +2/+4 | 3600 | 4710 | 3,42 | | AUT | | R452A 2560x855x1920 | n° 4 | 380 | 2 | - | Led Standard |





Voltaggio di serie - Standard voltage: 230v/1/50Hz • Classe climatica - Climatic class: MAX = (25°C - % U.R. 60)



| MOD. | | | | | | |
|-----------------------|---------------|-----|-------------------|-------------------|---------------------|--|
| | LxPxH mm | Kg | container n°(20') | container n°(40') | colore colour color | |
| SPACE 91.1 | 886x740x2180 | 200 | 18 | 39 | | |
| SPACE 131.1 | 1440x740x2180 | 250 | 12 | 24 | | |
| SPACE 151.1 | 1650x740x2180 | 275 | 9 | 21 | | |
| SPACE 201.1 | 2095x740x2180 | 350 | 6 | 15 | | |
| SPACE 91.1 INOX | 970x720x2180 | 200 | 18 | 39 | | |
| SPACE 131.1 INOX | 1440x740x2180 | 250 | 12 | 24 | | |
| SPACE 151.1 INOX | 1650x740x2180 | 275 | 9 | 21 | | |
| SPACE 201.1 INOX | 2095x740x2180 | 350 | 6 | 15 | | |
| SPACE PLUS 91.1 | 926x920x2180 | 235 | 12 | 24 | | |
| SPACE PLUS 131.1 | 1370x920x2180 | 300 | 8 | 16 | | |
| SPACE PLUS 151.1 | 1580x920x2180 | 320 | 6 | 14 | | |
| SPACE PLUS 201.1 | 2110x920x2180 | 360 | 4 | 12 | | |
| SPACE PLUS 259.1 | 2620x920x2180 | 450 | 4 | 8 | | |
| SPACE PLUS 91.1 INOX | 926x920x2180 | 235 | 12 | 24 | | |
| SPACE PLUS 131.1 INOX | 1370x920x2180 | 300 | 8 | 16 | | |
| SPACE PLUS 151.1 INOX | 1580x920x2180 | 330 | 6 | 14 | | |
| SPACE PLUS 201.1 INOX | 1995x920x2180 | 380 | 4 | 12 | | |
| SPACE PLUS 259.1 INOX | 2620x920x2180 | 470 | 4 | 8 | | |

NOTE

| Accessori - Accessories - Accessoires - Zubehör - Accesorios | | | MOD. | | | |
|--|---|-----|-----------------------|---------|----------------------|---------|
| | Barra per ganci porta blister / Bar hooks for blister / Stange für Blisterverpackungs Haken / Bar crochets pour blisters / Barra para ganchos porta-blister | | SPACE 131.1 | ACP1894 | | |
| | | | SPACE 131.1 INOX | | | |
| | | | SPACE PLUS 131.1 | | | |
| | | | SPACE PLUS 131.1 INOX | | | |
| | | | | | SPACE 151.1 | C410101 |
| | | | | | SPACE 151.1 INOX | |
| | | | | | SPACE PLUS 151.1 | |
| | | | | | SPACE 91.1 | ACP1893 |
| | | | | | SPACE 91.1 INOX | |
| | | | | | SPACE PLUS 91.1 | |
| | | | | | SPACE PLUS 91.1 INOX | |
| | | | | | SPACE PLUS 201.1 | ACP1896 |
| SPACE PLUS 201.1 INOX | | | | | | |
| | Ganci porta blister per prodotti da appendere / Blister hooks to hang products / Blister crochets pour accrocher les produits / Blisterhaken um Produkte hängen / Blister ganchos para colgar productos | 350 | SPACE PLUS 259.1 | ACP1897 | | |
| | | | SPACE PLUS 259.1 INOX | | | |
| | | | SPACE .1 | | | |
| | | | SPACE PLUS .1 INOX | | | |
| | | | SPACE PLUS .1 | C4103/2 | | |
| | | | SPACE PLUS .1 INOX | | | |

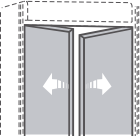
| Optional - Optionnel - Extra - Extras | | | MOD. |
|---------------------------------------|--|--------|-----------------------|
| | Coppia spalle cieche / Blind couple shoulder / Épaules couple aveugle / Blinde Paar Schulter / Pareja de hombros ciegos laterales | | SPACE .1 |
| | | | SPACE .1 INOX |
| | | | SPACE PLUS .1 |
| | Kit ruote con e senza freno / Kit wheels with and without brake / Kit roulettes avec et sans frein / Kit rollen mit und ohne Bremse / Kit ruedas con y sin freno | n° 2+2 | SPACE .1 |
| | | | SPACE .1 INOX |
| | | | SPACE PLUS .1 |
| | | | SPACE PLUS .1 INOX |
| | | n° 3+3 | SPACE PLUS 259.1 |
| | | | SPACE PLUS 259.1 INOX |

| Optional - Optionnel - Extra - Extras | | MOD. |
|---|--|-----------------------------------|
|  <p>Set luce (Led) / Set lighting system (Led) / Placez le système de d'éclairage (Led) / Stellen Sie Beleuchtungssystem ein (Led) / Sistema de iluminación (Led)</p> | <p>4 ripiani / 4 shelves / 4 étagères / 4 Ablagen / 4 estantes</p> | SPACE 91.1 |
| | | SPACE 131.1 |
| | | SPACE 151.1 |
| | | SPACE 201.1 |
| | | SPACE 91.1 INOX |
| | | SPACE 131.1 INOX |
| | | SPACE 151.1 INOX |
| | | SPACE 201.1 INOX |
| | | SPACE PLUS 91.1 |
| | | SPACE PLUS 131.1 |
| | | SPACE PLUS 151.1 |
| | | SPACE PLUS 201.1 |
| | | SPACE PLUS 259.1 |
| | | SPACE PLUS 91.1 INOX |
| SPACE PLUS 131.1 INOX | | |
| SPACE PLUS 151.1 INOX | | |
| SPACE PLUS 201.1 INOX | | |
| SPACE PLUS 259.1 INOX | | |
|  <p>Cambio colore frontale macchina / Front colour changing / Changer la couleur avant / äußere frontale Farbänderung der Theke / Cambio del color en la parte frontal</p> | | SPACE / SPACE PLUS 91 - 131 - 151 |
| | | SPACE / SPACE PLUS 201 - 259 |
|  <p>Cambio colore interno macchina / Inside colour changing / Changer la couleur intérieure / Innere Farbänderung der Theke / Cambio del color en el interior</p> | | SPACE / SPACE PLUS 91 - 131 - 151 |
| | | SPACE / SPACE PLUS 201 - 259 |
|  <p>Cambio colore spalle macchina / Shoulder colour changing / Changer la couleur des épaules / Farbänderung Seitenteile der Theke / Cambio del color de los hombros laterales</p> | | SPACE |
| | | SPACE PLUS |
|  <p>Porte battenti / Hinged doors / Portes battantes / Schlagtüre / Puertas batientes</p> | | SPACE 131.1 |
| | | SPACE 151.1 |
| | | SPACE 201.1 |
| | | SPACE 131.1 INOX |
| | | SPACE 151.1 INOX |
| | | SPACE 201.1 INOX |
| | | SPACE PLUS 131.1 |
| | | SPACE PLUS 151.1 |
| | | SPACE PLUS 201.1 |
| | | SPACE PLUS 259.1 |
| | | SPACE PLUS 131.1 INOX |
| | SPACE PLUS 151.1 INOX | |
| | SPACE PLUS 201.1 INOX | |
| | SPACE PLUS 259.1 INOX | |

| Optional - Optionnel - Extra - Extras | | MOD. |
|--|--|--|
|  <p>Supplemento per inversione porta / Supplement for door inversion / Supplément pour inversion de porte / Zuschlag für Türumkehrung / Suplemento para inversión de puertas</p> | | Per informazioni vi preghiamo di contattare il nostro ufficio commerciale / For information, please contact our export department / Pour informations, veuillez contacter notre service commercial / Für Informationen kontaktieren Sie bitte unsere Verkaufsabteilung / Si necesita información adicional, no dude en ponerse en contacto con nuestro departamento de venta |
|  <p>Supplemento per presa elettrica diversa dalla standard / Supplement for electric socket different than the standard / Supplément pour prise électrique différent de la norme / Aufpreis für Steckdose abweichend vom Standard / Suplemento para toma de corriente diferente al estándar</p> | | |

SERIE SUPER



Vetrine refrigerate con o senza carrello / Refrigerated showcases with or without trolley / Vitrines réfrigérées avec ou sans chariot / Wandregale, Gekühlte Vitrinen mit oder ohne Wagen / Vitrinas refrigeradas con/sin carrito

SUPER 750 C

Neon di serie / Neon standard
Néon standard / Neonlicht Standard
Neón estándar

Piano di lavoro, copri evaporatore e carenatura posteriore in inox 18/10 AISI 304 / Worktable, evaporator cover and back streamlining in stainless steel 18/10 AISI 304 / Plan de travail, couverture évaporateur et structure postérieure en inox 18/10 AISI 304 / Bearbeitungsplan, Bedeckung des Verdampfers und Rückseitige Struktur aus Nirosto 18/10 AISI 304 / Mesada de servicio, cubre evaporador y chapas que cubren el grupo motor y rejillas de ventilación construida en acero inoxidable 18/10



Porte scorrevoli di chiusura in plexiglass
Closed by plexiglass sliding doors
Porte coulissantes de fermeture en plexiglas
Schiebe Türe aus Plexiglas
Cierre lado servicio con puertas corredizas de plexiglas

Mensola intermedia in cristallo
Middle shelf in crystal
Tablette mitoyenne en cristal
Zwischensregal aus Krystall
Estante intermedia de cristal

Colori standard
Standard colors



SUPER



SUPER SS

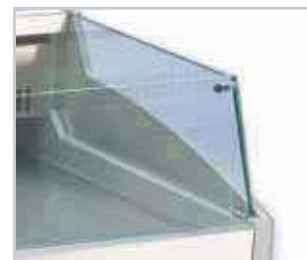

ACCESSORIO / ACCESSORY:

Carrello su ruote pivotanti, verniciato / Trolley on pivoting wheels, painted / Chariot sur roulettes pivotantes, vernis / Wagen mit drehzapfen Rädern / Soporte con ruedas pivotantes construido en tubo de hierro esmaltado

| | °C | Watt | m ² Superficie espositiva Display surface | STANDARD - mm. | DEFROST | H ₂ O | | | mm. (LxPxH) | Kg. | | | |
|---------------|-------|------|--|-------------------|---------|------------------|--|------|--------------|------|---|--------------|---|
| SUPER 750 | +2/+4 | 238 | 0,37 | 700x139 | | AUT | | R290 | 756x939x530 | 60 | - | LED Standard | 1 |
| SUPER 1000 | +2/+4 | 238 | 0,51 | 950x139 | | AUT | | R290 | 1006x939x530 | 74 | - | LED Standard | 1 |
| SUPER 1250 | +2/+4 | 238 | 0,65 | 1200x139 | | AUT | | R290 | 1256x939x530 | 84 | - | LED Standard | 1 |
| SUPER 1500 | +2/+4 | 326 | 0,78 | 1450x139 | | AUT | | R290 | 1506x939x530 | 97 | - | LED Standard | 1 |
| SUPER 2000 | +2/+4 | 326 | 1,079 | 1916x139 | | AUT | | R290 | 1972x939x530 | 118 | - | LED Standard | 1 |
| SUPER 750 C | +2/+4 | 238 | 0,37 | 700x139 | | AUT | | R290 | 756x939x530 | 60 | - | LED Standard | 1 |
| SUPER 1000 C | +2/+4 | 238 | 0,51 | 950x139 | | AUT | | R290 | 1006x939x530 | 74 | - | LED Standard | 1 |
| SUPER 1250 C | +2/+4 | 238 | 0,65 | 1200x139 | | AUT | | R290 | 1256x939x530 | 84 | - | LED Standard | 1 |
| SUPER 1500 C | +2/+4 | 326 | 0,78 | 1450x139 | | AUT | | R290 | 1506x939x530 | 97 | - | LED Standard | 1 |
| SUPER 2000 C | +2/+4 | 326 | 1,079 | 1916x139 | | AUT | | R290 | 1972x939x530 | 118 | - | LED Standard | 1 |
| SUPER 750 SS | +2/+4 | 238 | 0,37 | - | | AUT | | R290 | 756x939x296 | 52,5 | - | - | 1 |
| SUPER 1000 SS | +2/+4 | 238 | 0,51 | - | | AUT | | R290 | 1006x939x296 | 64 | - | - | 1 |
| SUPER 1250 SS | +2/+4 | 238 | 0,65 | - | | AUT | | R290 | 1256x939x296 | 71,5 | - | - | 1 |
| SUPER 1500 SS | +2/+4 | 326 | 0,78 | - | | AUT | | R290 | 1506x939x296 | 82 | - | - | 1 |
| SUPER 2000 SS | +2/+4 | 326 | 1,079 | - | | AUT | | R290 | 1972x939x296 | 98 | - | - | 1 |

Voltaggio di serie - Standard voltage: 230V/1/50Hz • Classe climatica - Climatic class: MAX = (25°C - % U.R. 60)

Vetrine refrigerate con o senza carrello / Refrigerated showcases with or without trolley / Vitrines réfrigérées avec ou sans chariot / Wandregale, Gekühlte Vitrinen mit oder ohne Wagen / Vitrinas refrigeradas con/sin carrito

SUPER 750 C DE

Colori standard
Standard colors

COD. 34

Neon di serie / Neon standard
Néon standard / Neonlicht Standard
Neón estándar

Porte scorrevoli di chiusura in plexiglass
Closed by plexiglass sliding doors
Porte coulissantes de fermeture en plexiglas
Schiebe Türe aus Plexiglas
Cierre lado servicio con puertas corredizas de plexiglas

Mensola intermedia in cristallo
Middle shelf in crystal / Tablette mitoyenne en cristal /
Zwischensegal aus Krystal / Estante intermedia de cristal

ACCESSORIO / ACCESSORY:
Piano refrigerato grazie
alla serpentina sul fondo
Refrigerated top thanks
to the coil on the bottom

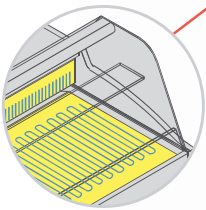

Con doppio evaporatore
With double evaporator
Avec double évaporateur
Mit Doppelverdampfer
Con doble evaporador

ACCESSORIO / ACCESSORY:

Carrello su ruote pivotanti, verniciato

Trolley on pivoting wheels, painted / Chariot sur roulettes pivotantes, vernis / Wagen mit drehzapfenen Rädern / Soporte con ruedas pivotantes construido en tubo de hierro esmaltado

Piano di lavoro, copri evaporatore e carenatura posteriore in inox 18/10 AISI 304 / Worktable, evaporator cover and back streamlining in stainless steel 18/10 AISI 304 / Plan de travail, couverture évaporateur et structure postérieure en inox 18/10 AISI 304 / Bearbeitungsplan, Bedeckung des Verdampfers und Rückseitige Struktur aus Nirosta 18/10 AISI 304 / Mesada de servicio, cubre evaporador y chapas que cubren el grupo motor y rejillas de ventilación construida en acero inoxidable 18/10

SUPER DE

SUPER SS DE



| | °C | Watt | m ² Superficie espositiva Display surface | STANDARD - mm. | DEFROST | H ₂ O | | | mm. (LxPxH) | Kg. | | | |
|------------------|-------|------|--|-------------------|---------|------------------|--|------|--------------|------|---|--------------|---|
| SUPER 750 DE | +2/+4 | 238 | 0,37 | 700x139 | | AUT | | R290 | 756x939x530 | 63 | - | LED Standard | 1 |
| SUPER 1000 DE | +2/+4 | 238 | 0,51 | 950x139 | | AUT | | R290 | 1006x939x530 | 77 | - | LED Standard | 1 |
| SUPER 1250 DE | +2/+4 | 238 | 0,65 | 1200x139 | | AUT | | R290 | 1256x939x530 | 87 | - | LED Standard | 1 |
| SUPER 1500 DE | +2/+4 | 326 | 0,78 | 1450x139 | | AUT | | R290 | 1506x939x530 | 97 | - | LED Standard | 1 |
| SUPER 2000 DE | +2/+4 | 326 | 1,079 | 1916x139 | | AUT | | R290 | 1972x939x530 | 122 | - | LED Standard | 1 |
| SUPER 750 C DE | +2/+4 | 238 | 0,37 | 700x139 | | AUT | | R290 | 756x939x530 | 63 | - | LED Standard | 1 |
| SUPER 1000 C DE | +2/+4 | 238 | 0,51 | 950x139 | | AUT | | R290 | 1006x939x530 | 77 | - | LED Standard | 1 |
| SUPER 1250 C DE | +2/+4 | 238 | 0,65 | 1200x139 | | AUT | | R290 | 1256x939x530 | 87 | - | LED Standard | 1 |
| SUPER 1500 C DE | +2/+4 | 326 | 0,78 | 1450x139 | | AUT | | R290 | 1506x939x530 | 97 | - | LED Standard | 1 |
| SUPER 2000 C DE | +2/+4 | 326 | 1,079 | 1916x139 | | AUT | | R290 | 1972x939x530 | 122 | - | LED Standard | 1 |
| SUPER 750 SS DE | +2/+4 | 238 | 0,37 | - | | AUT | | R290 | 756x939x296 | 55,5 | - | - | 1 |
| SUPER 1000 SS DE | +2/+4 | 238 | 0,51 | - | | AUT | | R290 | 1006x939x296 | 67 | - | - | 1 |
| SUPER 1250 SS DE | +2/+4 | 238 | 0,65 | - | | AUT | | R290 | 1256x939x296 | 74,5 | - | - | 1 |
| SUPER 1500 SS DE | +2/+4 | 326 | 0,78 | - | | AUT | | R290 | 1506x939x296 | 82 | - | - | 1 |
| SUPER 2000 SS DE | +2/+4 | 326 | 1,079 | - | | AUT | | R290 | 1972x939x296 | 102 | - | - | 1 |

Vollaggio di serie - Standard voltage: 230v/1/50Hz • Classe climatica - Climatic class: MAX = (25°C - % U.R. 60)

Vetrine refrigerate con o senza carrello / Refrigerated showcases with or without trolley / Vitrines réfrigérées avec ou sans chariot / Wandregale, Gekühlte Vitrinen mit oder ohne Wagen / Vitrinas refrigeradas con/sin carrito

SUPER 1200 EURONORM C

Porte scorrevoli di chiusura in plexiglass
 Closed by plexiglass sliding doors
 Porte coulissantes de fermeture en plexiglas
 Schiebe Türe aus Plexiglas
 Cierre lado servicio con puertas corredizas de plexiglás

Neon di serie / Neon standard
 Néon standard / Neonlicht Standard
 Neón estándar



Mensola intermedia in cristallo
 Middle shelf in crystal
 Tablette mitoyenne en cristal
 Zwischenregal aus Krystall
 Estante intermedia de cristal

ACCESSORIO / ACCESSORY:
 Carrello su ruote pivotanti, verniciato
 Trolley on pivoting wheels, painted
 Chariot sur roulettes pivotantes, vernis
 Wagen mit drehzapfenen Rädern
 Soporte con ruedas pivotantes construido en tubo de hierro esmaltado

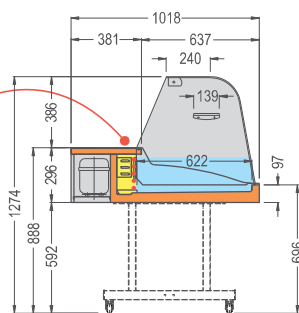

ACCESSORI / ACCESSORIES: I vassoi sono forniti a richiesta / Trays are supplied on request / Les plateaux sont fournis sur demande / Die Behälter werden auf Anfrage geliefert / Las bandejas se suministran a petición

SUPER 800 EURONORM C

SUPER 1200 EURONORM C

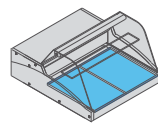

N° 2 vassoi 60x40
 N° 2 trays 60x40
 N° 2 plateaux 60x40
 N° 2 Behälter 60x40
 N° 2 bandejas 60x40

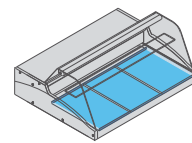

N° 3 vassoi 60x40
 N° 3 trays 60x40
 N° 3 plateaux 60x40
 N° 3 Behälter 60x40
 N° 3 bandejas 60x40

Piano di lavoro, copri evaporatore e carenatura posteriore in inox 18/10 AISI 304 / Worktable, evaporator cover and back streamlining in stainless steel 18/10 AISI 304 / Plan de travail, couverture évaporateur et structure postérieure en inox 18/10 AISI 304 / Bearbeitungsplan, Bedeckung des Verdampfers und Rückseitige Struktur aus Nirosta 18/10 AISI 304 / Mesada de servicio, cubre evaporador y chapas que cubren el grupo motor y rejillas de ventilación construida en acero inoxidable 18/10

| | °C | Watt | m ² Superficie espositiva Display surface | STANDARD - mm. | REFROST | H ₂ O | | mm. (LxPxH) | Kg. | | LED Standard | |
|-----------------------|-------|------|--|-------------------|---------|------------------|--|---------------|-----|---|--------------|---|
| SUPER 800 EURONORM C | +2/+4 | 238 | 0,51 | 850x139 | | AUT | | 906x1018x702 | 74 | - | LED Standard | 1 |
| SUPER 1200 EURONORM C | +2/+4 | 238 | 0,77 | 1260x139 | | AUT | | 1313x1018x702 | 84 | - | LED Standard | 1 |

Voltaggio di serie - Standard voltage: 230v/1/50Hz • Classe climatica - Climatic class: MAX = (25°C - % U.R. 60)

* Produzione a richiesta: per favore contattare l'ufficio commerciale / Production on request: please contact the sales dept.

FRUTTA
FRUIT / FRUITS
OBST / FRUTAS
°C +4 / +8



SALUMI
CURED MEATS / CHARCUTERIE
WURSTWAREN / CHARCUTERIA
°C +2 / +4



VERDURE
VEGETABLES / LEGUMES
GEMÜSE / VERDURAS
°C +4 / +6



LATTICINI
DAIRY PRODUCTS / LAITIERS
MILCH PRODUKTE / LACTEOS
°C +2 / +4



VINO E BIRRA
WINE AND BEER / VIN ET BIÈRE
WEIN UND BIER / BEBIDAS
°C +4 / +18



SUPER

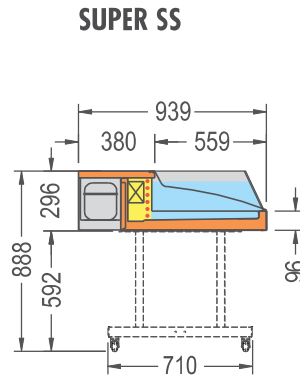
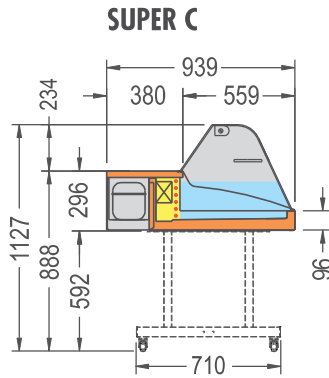
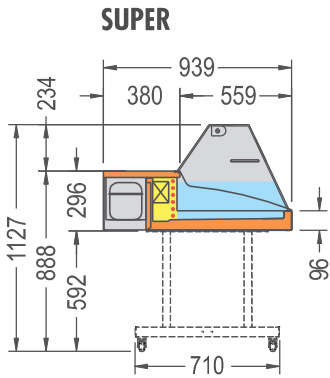

Sbrinamenti nelle 24 h.
Defrosting in 24 h.
Dégivrages en 24 heures
Auftauen innerhalb 24 Stunden
Descongelación en las 24 h.
N° 4

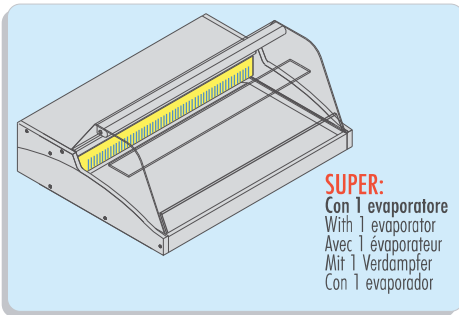

SUPER DE

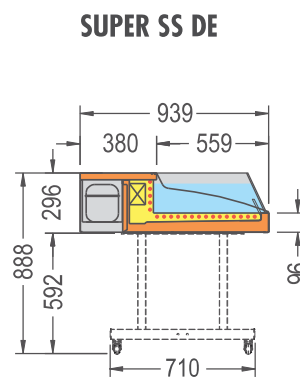
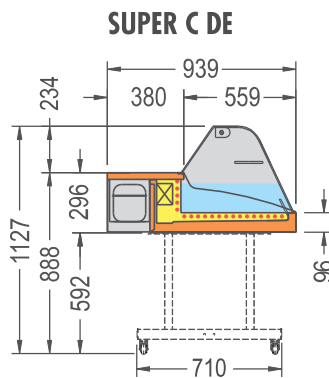
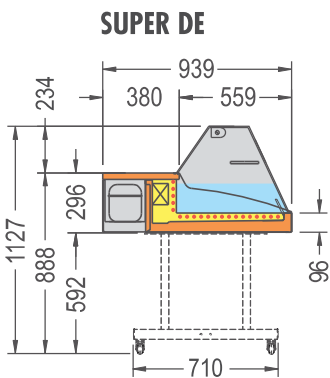



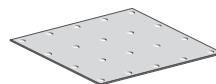

Sbrinamenti nelle 24 h.
Defrosting in 24 h.
Dégivrages en 24 heures
Auftauen innerhalb 24 Stunden
Descongelación en las 24 h.
N° 4

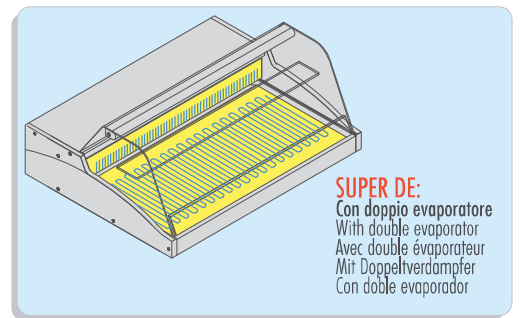

ACCESSORIO / ACCESSORY:
Piano distanziale inox forato
Stainless steel spacer bored surface
Plan spacer troué en acier inox
Gelochte fläche aus rostfreiem stahl
Plano perforado de acero inox
SUPER DE 750 = mm 700x559
SUPER DE 1000 = mm 950x559
SUPER DE 1250 = mm 1200x559
SUPER DE 1500 = mm 1450x559
SUPER DE 2000 = mm 1916x559



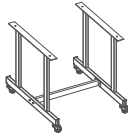
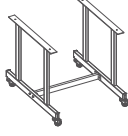

| MOD. | LxPxH mm | Kg |  | |  | |
|---------------|---------------|-------|---|----------------------|---|--|
| | | | container n°(20') | container n°(40') | colore colour color | |
| SUPER 750 | 1040x1000x580 | 80 | 40 | 88 | COD.34 | |
| SUPER 1000 | 1040x1000x580 | 94 | 40 | 88 | COD.34 | |
| SUPER 1250 | 1560x1000x580 | 124 | 24 | 56 | COD.34 | |
| SUPER 1500 | 1560x1000x580 | 127 | 24 | 56 | COD.34 | |
| SUPER 2000 | 2010x1000x580 | 158 | 16 | 40 | COD.34 | |
| SUPER 750 C | 1040x1000x580 | 80 | 40 | 88 | COD.34 | |
| SUPER 1000 C | 1040x1000x580 | 94 | 40 | 88 | COD.34 | |
| SUPER 1250 C | 1560x1000x580 | 30 | 24 | 56 | COD.34 | |
| SUPER 1500 C | 1560x1000x580 | 127 | 24 | 56 | COD.34 | |
| SUPER 2000 C | 2010x1000x580 | 158 | 16 | 40 | COD.34 | |
| SUPER 750 SS | 1040x1000x580 | 72,5 | 40 | 88 | COD.34 | |
| SUPER 1000 SS | 1040x1000x580 | 84 | 40 | 88 | COD.34 | |
| SUPER 1250 SS | 1560x1000x580 | 101,5 | 24 | 56 | COD.34 | |
| SUPER 1500 SS | 1560x1000x580 | 112 | 24 | 56 | COD.34 | |
| SUPER 2000 SS | 2010x1000x580 | 138 | 16 | 40 | COD.34 | |
| SUPER 750 DE | 1040x1000x580 | 83 | 40 | 88 | COD.34 | |

| MOD. | LxPxH mm | Kg |  | |  | |
|-----------------------|---------------|-------|---|----------------------|---|--|
| | | | container n°(20') | container n°(40') | colore colour color | |
| SUPER 1000 DE | 1040x1000x580 | 97 | 40 | 88 | COD.34 | |
| SUPER 1250 DE | 1560x1000x580 | 117 | 24 | 56 | COD.34 | |
| SUPER 1500 DE | 1560x1000x580 | 117 | 24 | 56 | COD.34 | |
| SUPER 2000 DE | 2010x1000x580 | 162 | 16 | 40 | COD.34 | |
| SUPER 750 C DE | 1040x1000x580 | 83 | 40 | 88 | COD.34 | |
| SUPER 1000 C DE | 1040x1000x580 | 97 | 40 | 88 | COD.34 | |
| SUPER 1250 C DE | 1560x1000x580 | 117 | 24 | 56 | COD.34 | |
| SUPER 1500 C DE | 1560x1000x580 | 117 | 24 | 56 | COD.34 | |
| SUPER 2000 C DE | 2010x1000x580 | 162 | 16 | 40 | COD.34 | |
| SUPER 750 SS DE | 1040x1000x580 | 75,5 | 40 | 88 | COD.34 | |
| SUPER 1000 SS DE | 1040x1000x580 | 87 | 40 | 88 | COD.34 | |
| SUPER 1250 SS DE | 1560x1000x580 | 104,5 | 24 | 56 | COD.34 | |
| SUPER 1500 SS DE | 1560x1000x580 | 112 | 24 | 56 | COD.34 | |
| SUPER 2000 SS DE | 2020x1000x580 | 142 | 16 | 40 | COD.34 | |
| SUPER 800 EURONORM C | 1360x1080x880 | 99 | 16 | 32 | COD.34 | |
| SUPER 1200 EURONORM C | 1360x1080x880 | 114 | 16 | 32 | COD.34 | |

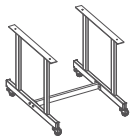
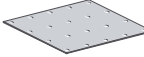
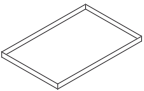
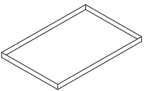
| Accessori - Accessories - Accessoires - Zuberhör - Accesorios | | MOD. |  Codice |
|--|------------------|-----------------------|---|
|  Carrello / Trolley / Chariot / Wagen / Carro | | SUPER 750 | 21401/01 |
| | | SUPER 750 C | 21401/01 |
| | | SUPER 750 C DE | 21401/01 |
| | | SUPER 750 DE | 21401/01 |
| | | SUPER 750 SS | 21401/01 |
| | | SUPER 750 SS DE | 21401/01 |
| | | SUPER 800 EURONORM C | 21401/01 |
| | | SUPER 1000 | 21501/01 |
| | | SUPER 1000 C | 21501/01 |
| | | SUPER 1000 C DE | 21501/01 |
| | | SUPER 1000 DE | 21501/01 |
| | | SUPER 1000 SS | 21501/01 |
| | | SUPER 1000 SS DE | 21501/01 |
| | | SUPER 1200 EURONORM C | 21601/01 |
| | | SUPER 1250 | 21601/01 |
| | | SUPER 1250 C | 21601/01 |
| | | SUPER 1250 C DE | 21601/01 |
| | | SUPER 1250 DE | 21601/01 |
| | | SUPER 1250 SS | 21601/01 |
| | | SUPER 1250 SS DE | 21601/01 |
| | | SUPER 1500 | 21601/01 |
| | | SUPER 1500 C | 21601/01 |
| | | SUPER 1500 C DE | 21601/01 |
| | | SUPER 1500 DE | 21601/01 |
| | | SUPER 1500 SS | 21601/01 |
| | SUPER 1500 SS DE | 21601/01 | |
| | SUPER 2000 | 34001/01 | |
| | SUPER 2000 C | 34001/01 | |
| | SUPER 2000 C DE | 34001/01 | |
| | SUPER 2000 DE | 34001/01 | |
| | SUPER 2000 SS | 34001/01 | |
| | SUPER 2000 SS DE | 34001/01 | |
|  Carrello (ruote con e senza freno) / Trolley (wheels with and without brake) / Chariot (roues avec et sans frein) / Wagen (Räder mit und ohne Bremse) / Carro (ruedas con y sin freno) | | SUPER 750 | 21401/02 |
| | | SUPER 750 C | 21401/02 |
| | | SUPER 750 C DE | 21401/02 |
| | | SUPER 750 DE | 21401/02 |
| | | SUPER 750 SS | 21401/02 |
| | | SUPER 750 SS DE | 21401/02 |
| | | SUPER 800 EURONORM C | 21401/02 |
| | | SUPER 1000 | 21501/02 |
| | | SUPER 1000 C | 21501/02 |
| | | SUPER 1000 C DE | 21501/02 |
| | | SUPER 1000 DE | 21501/02 |
| | | SUPER 1000 SS | 21501/02 |
| | | SUPER 1000 SS DE | 21501/02 |
| | | SUPER 1200 EURONORM C | 21601/02 |
| | | SUPER 1250 | 21601/02 |

| Accessori - Accessories - Accessoires - Zuberhör - Accesorios | | MOD. | Codice |
|--|---------------|-----------------------|----------|
|  <p>Carrello (ruote con e senza freno) / Trolley (wheels with and without brake) / Chariot (roues avec et sans frein) / Wagen (Räder mit und ohne Bremse) / Carro (ruedas con y sin freno)</p> | | SUPER 1250 C | 21601/02 |
| | | SUPER 1250 C DE | 21601/02 |
| | | SUPER 1250 DE | 21601/02 |
| | | SUPER 1250 SS | 21601/02 |
| | | SUPER 1250 SS DE | 21601/02 |
| | | SUPER 1500 | 21601/02 |
| | | SUPER 1500 C | 21601/02 |
| | | SUPER 1500 C DE | 21601/02 |
| | | SUPER 1500 DE | 21601/02 |
| | | SUPER 1500 SS | 21601/02 |
| | | SUPER 1500 SS DE | 21601/02 |
| | | SUPER 2000 | 34001/02 |
| | | SUPER 2000 C | 34001/02 |
| | | SUPER 2000 C DE | 34001/02 |
| | | SUPER 2000 DE | 34001/02 |
| | | SUPER 2000 SS | 34001/02 |
| SUPER 2000 SS DE | 34001/02 | | |
|  <p>Piano inox forato / Stainless steel bored surface / Plan troué en acier inox / Gelochte fläche aus rostfreiem stahl / Plano perforado de acero inox</p> | | SUPER 750 C DE | X03207 |
| | | SUPER 750 DE | X03207 |
| | | SUPER 750 SS DE | X03207 |
| | | SUPER 1000 C DE | X03208 |
| | | SUPER 1000 DE | X03208 |
| | | SUPER 1000 SS DE | X03208 |
| | | SUPER 1250 C DE | X03209 |
| | | SUPER 1250 DE | X03209 |
| | | SUPER 1250 SS DE | X03209 |
| | | SUPER 1500 C DE | X03210 |
| | | SUPER 1500 DE | X03210 |
| | | SUPER 1500 SS DE | X03210 |
| | | SUPER 2000 C DE | X03211 |
| SUPER 2000 DE | X03211 | | |
| SUPER 2000 SS DE | X03211 | | |
|  <p>Teglia in alluminio / Aluminium baking pan / Plat à rôtir en aluminium / Backform aus Aluminium / Bandeja para horno de aluminio</p> | 600x400x20 mm | SUPER 800 EURONORM C | E4301 |
| | | SUPER 1200 EURONORM C | E4301 |
|  <p>Teglia inox / Stainless steel pan / Plaque inox / Inox-Backblech / Bandeja inox</p> | 600x400x20 mm | SUPER 800 EURONORM C | E4201 |
| | | SUPER 1200 EURONORM C | E4201 |

| Optional - Optionnel - Extra - Extras | | MOD. |
|--|--|--|
|  <p>Supplemento per inversione porta / Supplement for door inversion / Supplément pour inversion de porte / Zuschlag für Türumkehrung / Suplemento para inversión de puertas</p> | | Per informazioni vi preghiamo di contattare il nostro ufficio commerciale / For information, please contact our export department / Pour informations, veuillez contacter notre service commercial / Für Informationen kontaktieren Sie bitte unsere Verkaufsabteilung / Si necesita información adicional, no dude en ponerse en contacto con nuestro departamento de venta |
|  <p>Supplemento per presa elettrica diversa dalla standard / Supplement for electric socket different than the standard / Supplément pour prise électrique différent de la norme / Aufpreis für Steckdose abweichend vom Standard / Suplemento para toma de corriente diferente al estándar</p> | | |

SERIE DELICIOUS



Piano di lavoro, copri evaporatore e carenatura posteriore in inox 18/10 AISI 304 / Worktable, evaporator cover and back streamlining in stainless steel 18/10 AISI 304 / Plan de travail, couverture évaporateur et structure postérieure en inox 18/10 AISI 304 / Bearbeitungsplan, Bedeckung des Verdampfers und Rückseitige Struktur aus Nirosta 18/10 AISI 304 / Mesada de servicio, cubre evaporador y chapas que cubren el grupo motor y rejillas de ventilación construida en acero inoxidable 18/10

DELICIOUS 1000 SS

DELICIOUS



DELICIOUS C

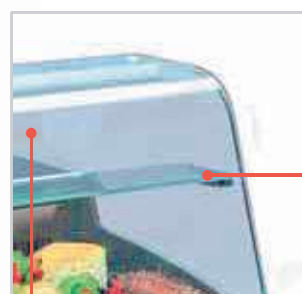

Mensola intermedia in cristallo
Middle shelf in crystal
Tablette mitoyenne en cristal
Zwischensregal aus Krystall
Estante intermedia de cristal



ACCESSORIO / ACCESSORY:

Carrello su ruote pivotanti, verniciato
Trolley on pivoting wheels, painted
Chariot sur roulettes pivotantes, vernis
Wagen mit drehzapfenen Rädern

Soporte con ruedas pivotantes construido en tubo de hierro esmaltado

DELICIOUS / DELICIOUS C:

Porte scorrevoli di chiusura in plexiglass
Closed by plexiglass sliding doors

Porte coulissantes de fermeture en plexiglas
Schiebe Türe aus Plexiglas

Cierre lado servicio con puertas corredizas de plexiglas

| | °C | Watt | m ² Superficie espositiva Display surface | STANDARD - mm. | DEFROST | H ₂ O | | | mm. (LxPxH) | Kg. | | LED Standard | |
|-------------------|-------|------|--|-------------------|---------|------------------|--|------|--------------|------|---|--------------|---|
| DELICIOUS 750 | +2/+4 | 238 | 0,37 | 700x139 | | AUT | | R290 | 756x790x810 | 59 | - | LED Standard | 1 |
| DELICIOUS 1000 | +2/+4 | 238 | 0,51 | 950x139 | | AUT | | R290 | 1006x790x810 | 73 | - | LED Standard | 1 |
| DELICIOUS 1250 | +2/+4 | 238 | 0,65 | 1200x139 | | AUT | | R290 | 1256x790x810 | 83 | - | LED Standard | 1 |
| DELICIOUS 1500 | +2/+4 | 326 | 0,78 | 1450x139 | | AUT | | R290 | 1506x790x810 | 96 | - | LED Standard | 1 |
| DELICIOUS 2000 | +2/+4 | 326 | 1,079 | 1916x139 | | AUT | | R290 | 1972x790x810 | 116 | - | LED Standard | 1 |
| DELICIOUS 750 C | +2/+4 | 238 | 0,37 | 700x139 | | AUT | | R290 | 756x790x810 | 59 | - | LED Standard | 1 |
| DELICIOUS 1000 C | +2/+4 | 238 | 0,51 | 950x139 | | AUT | | R290 | 1006x790x810 | 73 | - | LED Standard | 1 |
| DELICIOUS 1250 C | +2/+4 | 238 | 0,65 | 1200x139 | | AUT | | R290 | 1256x790x810 | 83 | - | LED Standard | 1 |
| DELICIOUS 1500 C | +2/+4 | 326 | 0,78 | 1450x139 | | AUT | | R290 | 1506x790x810 | 96 | - | LED Standard | 1 |
| DELICIOUS 2000 C | +2/+4 | 326 | 1,079 | 1916x139 | | AUT | | R290 | 1972x790x810 | 116 | - | LED Standard | 1 |
| DELICIOUS 750 SS | +2/+4 | 238 | 0,37 | - | | AUT | | R290 | 756x790x575 | 51,5 | - | - | 1 |
| DELICIOUS 1000 SS | +2/+4 | 238 | 0,51 | - | | AUT | | R290 | 1006x790x575 | 63 | - | - | 1 |
| DELICIOUS 1250 SS | +2/+4 | 238 | 0,65 | - | | AUT | | R290 | 1256x790x575 | 70,5 | - | - | 1 |
| DELICIOUS 1500 SS | +2/+4 | 326 | 0,78 | - | | AUT | | R290 | 1506x790x575 | 81 | - | - | 1 |
| DELICIOUS 2000 SS | +2/+4 | 326 | 1,079 | - | | AUT | | R290 | 1972x790x575 | 96 | - | - | 1 |

Voltaggio di serie - Standard voltage: 230v/1/50Hz • Classe climatica - Climatic class: MAX = (25°C - % U.R. 60)

DELICIOUS 1000 DE



Neon di serie / Neon standard
Néon standard / Neonlicht Standard
Neón estándar

Porte scorrevoli di chiusura in plexiglass
Closed by plexiglass sliding doors
Porte coulissantes de fermeture en plexiglas
Schiebe Türe aus Plexiglas
Cierre lado servicio con puertas corredizas de plexiglas

Mensola intermedia in cristallo
Middle shelf in crystal
Tablette mitoyenne en cristal
Zwischensregal aus Krystall
Estante intermedia de cristal

ACCESSORIO / ACCESSORY:
Piano distanziale inox forato
Stainless steel spacer bored surface
Plan spacer troue en acier inox
Gelochte Fläche aus rostfreiem stahl
Plano perforado de acero inox

Colori standard
Standard colors



ACCESSORIO / ACCESSORY:
Piano refrigerato grazie alla serpentina sul fondo
Refrigerated top thanks to the coil on the bottom

ACCESSORIO / ACCESSORY:
Carrello su ruote pivotanti, verniciato
Trolley on pivoting wheels, painted
Chariot sur roulettes pivotantes, vernis
Wagen mit drehzapfen Rädern
Soporte con ruedas pivotantes construido en tubo de hierro esmaltado

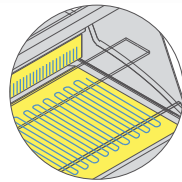

Con doppio evaporatore
With double evaporator
Avec double évaporateur
Mit Doppelverdampfer
Con doble evaporador

DELICIOUS C DE



DELICIOUS SS DE



Piano di lavoro, copri evaporatore e carenatura posteriore in inox 18/10 AISI 304 / Worktable, evaporator cover and back streamlining in stainless steel 18/10 AISI 304 / Plan de travail, couverture évaporateur et structure postérieure en inox 18/10 AISI 304 / Bearbeitungsplan, Bedeckung des Verdampfers und Rückseitige Struktur aus Nirosta 18/10 AISI 304 / Mesada de servicio, cubre evaporador y chapas que cubren el grupo motor y rejillas de ventilación construida en acero inoxidable 18/10

| | °C | Watt | m ² Superficie espositiva Display surface | STANDARD - mm. | | H ₂ O | | | mm. (LxPxH) | Kg. | | | |
|----------------------|-------|------|--|-------------------|--|------------------|--|--|-------------|--------------|------|---|----------------|
| DELICIOUS 750 DE | +2/+4 | 238 | 0,37 | 700x139 | | AUT | | | R290 | 756x790x810 | 62 | - | LED Standard 1 |
| DELICIOUS 1000 DE | +2/+4 | 238 | 0,51 | 950x139 | | AUT | | | R290 | 1006x790x810 | 76 | - | LED Standard 1 |
| DELICIOUS 1250 DE | +2/+4 | 238 | 0,65 | 1200x139 | | AUT | | | R290 | 1256x790x810 | 86 | - | LED Standard 1 |
| DELICIOUS 1500 DE | +2/+4 | 326 | 0,78 | 1450x139 | | AUT | | | R290 | 1506x790x810 | 99 | - | LED Standard 1 |
| DELICIOUS 2000 DE | +2/+4 | 326 | 1,079 | 1916x139 | | AUT | | | R290 | 1972x790x810 | 119 | - | LED Standard 1 |
| DELICIOUS 750 C DE | +2/+4 | 238 | 0,37 | 700x139 | | AUT | | | R290 | 756x790x810 | 62 | - | LED Standard 1 |
| DELICIOUS 1000 C DE | +2/+4 | 238 | 0,51 | 950x139 | | AUT | | | R290 | 1006x790x810 | 76 | - | LED Standard 1 |
| DELICIOUS 1250 C DE | +2/+4 | 238 | 0,65 | 1200x139 | | AUT | | | R290 | 1256x790x810 | 86 | - | LED Standard 1 |
| DELICIOUS 1500 C DE | +2/+4 | 326 | 0,78 | 1450x139 | | AUT | | | R290 | 1506x790x810 | 99 | - | LED Standard 1 |
| DELICIOUS 2000 C DE | +2/+4 | 326 | 1,079 | 1916x139 | | AUT | | | R290 | 1972x790x810 | 119 | - | LED Standard 1 |
| DELICIOUS 750 SS DE | +2/+4 | 238 | 0,37 | - | | AUT | | | R290 | 756x790x575 | 54,5 | - | - 1 |
| DELICIOUS 1000 SS DE | +2/+4 | 238 | 0,51 | - | | AUT | | | R290 | 1006x790x575 | 66 | - | - 1 |
| DELICIOUS 1250 SS DE | +2/+4 | 238 | 0,65 | - | | AUT | | | R290 | 1256x790x575 | 73,5 | - | - 1 |
| DELICIOUS 1500 SS DE | +2/+4 | 326 | 0,78 | - | | AUT | | | R290 | 1506x790x575 | 84 | - | - 1 |
| DELICIOUS 2000 SS DE | +2/+4 | 326 | 1,079 | - | | AUT | | | R290 | 1972x790x575 | 99 | - | - 1 |

Voltaggio di serie - Standard voltage: 230v/1/50Hz • Classe climatica - Climatic class: MAX = (25°C - % U.R. 60)



DELICIOUS 800 EURONORM C

Porte scorrevoli di chiusura in plexiglass / Closed by plexiglass sliding doors / Porte coulissantes de fermeture en plexiglas / Schiebe Türe aus Plexiglas / Cierre lado servicio con puertas corredizas de plexiglás

Neon di serie / Neon standard
Néon standard / Neonlicht Standard
Neón estándar

Mensola intermedia in cristallo
Middle shelf in crystal
Tablette mitoyenne en cristal
Zwischensregal aus Krystall
Estante intermedia de cristal



ACCESSORIO / ACCESSORY:

Carrello su ruote pivotanti, verniciato
Trolley on pivoting wheels, painted
Chariot sur roulettes pivotantes, vernis
Wagen mit drehzapfenen Rädern
Soporte con ruedas pivotantes construido en tubo de hierro esmaltado



Colori standard
Standard colors

COD. 34

ACCESSORI / ACCESSORIES: I vassoi sono forniti a richiesta / Trays are supplied on request / Les plateaux sont fournis sur demande / Die Behälter werden auf Anfrage geliefert / Las bandejas se suministran a petición

DELICIOUS 800 EURONORM C

DELICIOUS 1200 EURONORM C

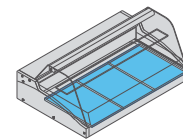
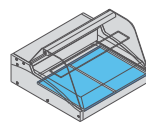

N° 2 vassoi 60x40
N° 2 trays 60x40
N° 2 plateaux 60x40
N° 2 Behälter 60x40
N° 2 bandejas 60x40

N° 3 vassoi 60x40
N° 3 trays 60x40
N° 3 plateaux 60x40
N° 3 Behälter 60x40
N° 3 bandejas 60x40

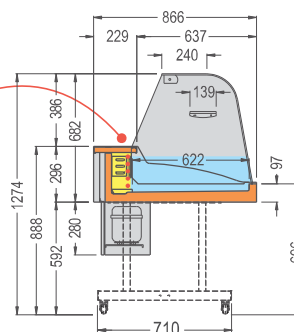
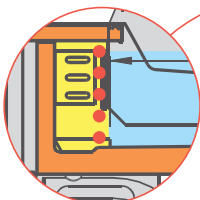

| | °C | Watt | m ² Superficie espositiva Display surface | STANDARD - mm. | DEPROSE | H ₂ O | | mm. (LxPxH) | Kg. | | | | |
|---------------------------|-------|------|--|-------------------|---------|------------------|--|-------------|--------------|----|---|--------------|---|
| DELICIOUS 800 EURONORM C | +2/+4 | 238 | 0,51 | 850x139 | | AUT | | R290 | 906x866x962 | 73 | - | LED Standard | 1 |
| DELICIOUS 1200 EURONORM C | +2/+4 | 238 | 0,77 | 1260x139 | | AUT | | R290 | 1313x866x962 | 83 | - | LED Standard | 1 |

Voltaggio di serie - Standard voltage: 230v/1/50Hz • Classe climatica - Climatic class: MAX = (25°C - % U.R. 60)



DELICIOUS

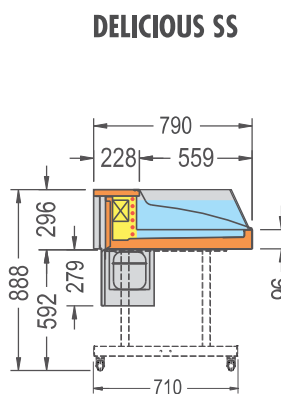
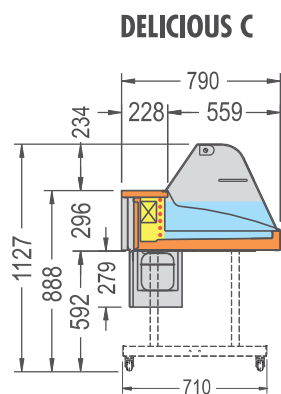
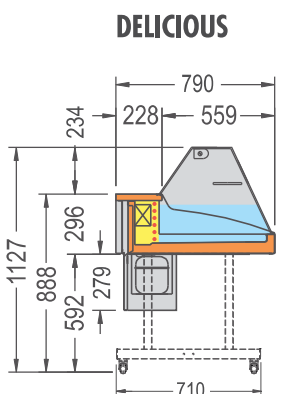

Sbrinamenti nelle 24 h.
Defrosting in 24 h.
Dégivrage en 24 heures
Auftauen innerhalb 24 Stunden
Descongelación en las 24 h.
N° 4

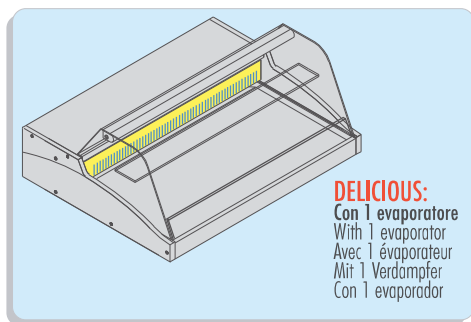

DELICIOUS DE

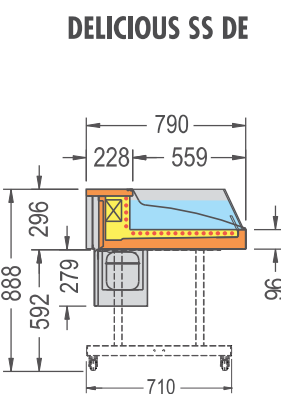
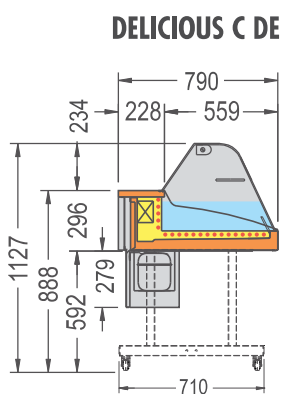
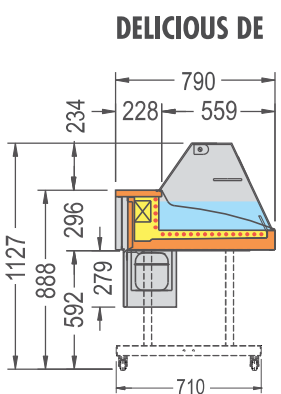

Sbrinamenti nelle 24 h.
Defrosting in 24 h.
Dégivrage en 24 heures
Auftauen innerhalb 24 Stunden
Descongelación en las 24 h.
N° 4

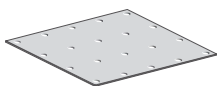

ACCESSORIO / ACCESSORY:
Piano distanziale inox forato
Stainless steel spacer bored surface
Plan spacer troué en acier inox
Gelochte fläche aus rostfreiem stahl
Plano perforado de acero inox
DELICIOUS DE 750 = mm 700x559
DELICIOUS DE 1000 = mm 950x559
DELICIOUS DE 1250 = mm 1200x559
DELICIOUS DE 1500 = mm 1450x559
DELICIOUS DE 2000 = mm 1916x559

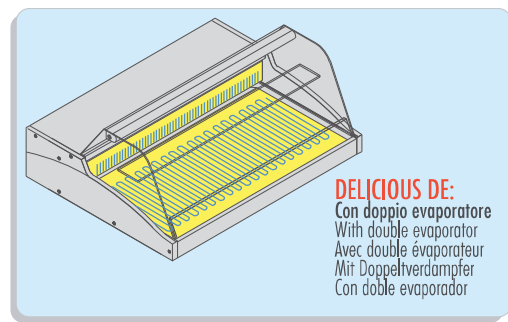

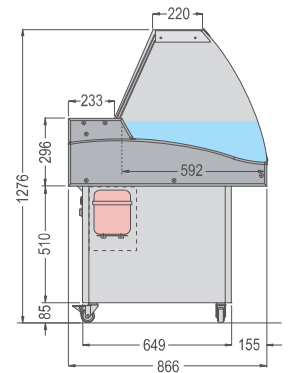
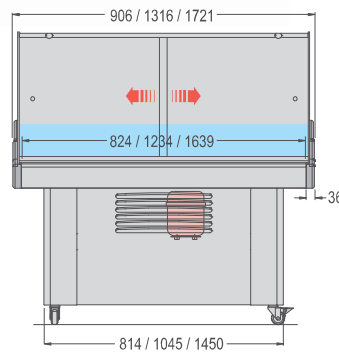
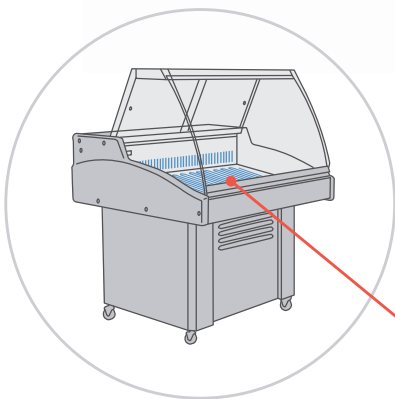

ADRIATICA





| | °C | mm. (LxPxH) | m ² | Watt | | H ₂ O | | | Kg. | | | |
|----------------|-------|---------------|----------------|------|--|------------------|--|------|-----|---|--------------|---|
| ADRIATICA 900 | -1/+8 | 906x866x1276 | 0,48 | 300 | | MAN | | R290 | 94 | - | LED Standard | * |
| ADRIATICA 1300 | -1/+8 | 1316x866x1276 | 0,73 | 340 | | MAN | | R290 | 104 | - | LED Standard | |
| ADRIATICA 1700 | -1/+8 | 1721x866x1276 | 0,97 | 350 | | MAN | | R290 | 117 | - | LED Standard | * |

Voltaggio di serie - Standard voltage: 230v/1/50Hz • Classe climatica - Climatic class: MAX = (25°C - 1/3 U.R. 60)



* Produzione a richiesta: per favore contattare l'ufficio commerciale / Production on request: please contact the sales dept.

| MOD. | LxPxH mm | Kg |  | |  |
|-------------------|---------------|-------|---|----------------------|---|
| | | | container n°(20') | container n°(40') | |
| DELICIOUS 750 | 1040x1000x840 | 84 | 20 | 44 | COD.34 |
| DELICIOUS 1000 | 1040x1000x840 | 98 | 20 | 44 | COD.34 |
| DELICIOUS 1250 | 1560x1000x840 | 118 | 12 | 28 | COD.34 |
| DELICIOUS 1500 | 1560x1000x840 | 131 | 12 | 28 | COD.34 |
| DELICIOUS 2000 | 2010x1000x840 | 156 | 8 | 20 | COD.34 |
| DELICIOUS 750 C | 1040x1000x840 | 84 | 20 | 44 | COD.34 |
| DELICIOUS 1000 C | 1040x1000x840 | 98 | 20 | 44 | COD.34 |
| DELICIOUS 1250 C | 1560x1000x840 | 118 | 12 | 28 | COD.34 |
| DELICIOUS 1500 C | 1560x1000x840 | 131 | 12 | 28 | COD.34 |
| DELICIOUS 2000 C | 2010x1000x840 | 156 | 8 | 20 | COD.34 |
| DELICIOUS 750 SS | 1040x1000x840 | 76,5 | 20 | 44 | COD.34 |
| DELICIOUS 1000 SS | 1040x1000x840 | 88 | 20 | 44 | COD.34 |
| DELICIOUS 1250 SS | 1560x1000x840 | 100,5 | 12 | 28 | COD.34 |
| DELICIOUS 1500 SS | 1560x1000x840 | 116 | 12 | 28 | COD.34 |
| DELICIOUS 2000 SS | 2010x1000x840 | 136 | 8 | 20 | COD.34 |
| DELICIOUS 750 DE | 1040x1000x840 | 87 | 20 | 44 | COD.34 |
| DELICIOUS 1000 DE | 1040x1000x840 | 101 | 20 | 44 | COD.34 |
| DELICIOUS 1250 DE | 1560x1000x840 | 111 | 12 | 28 | COD.34 |

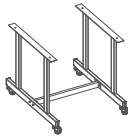
| MOD. | LxPxH mm | Kg |  | |  |
|---------------------------|----------------|-------|---|----------------------|---|
| | | | container n°(20') | container n°(40') | |
| DELICIOUS 1500 DE | 1560x1000x840 | 134 | 12 | 28 | COD.34 |
| DELICIOUS 2000 DE | 2010x1000x840 | 159 | 8 | 20 | COD.34 |
| DELICIOUS 750 C DE | 1040x1000x840 | 87 | 20 | 44 | COD.34 |
| DELICIOUS 1000 C DE | 1040x1000x840 | 101 | 20 | 44 | COD.34 |
| DELICIOUS 1250 C DE | 1560x1000x840 | 111 | 12 | 28 | COD.34 |
| DELICIOUS 1500 C DE | 1560x1000x840 | 134 | 12 | 28 | COD.34 |
| DELICIOUS 2000 C DE | 2010x1000x840 | 159 | 8 | 20 | COD.34 |
| DELICIOUS 750 SS DE | 1040x1000x840 | 79,5 | 20 | 44 | COD.34 |
| DELICIOUS 1000 SS DE | 1040x1000x840 | 91 | 20 | 44 | COD.34 |
| DELICIOUS 1250 SS DE | 1560x1000x840 | 103,5 | 12 | 28 | COD.34 |
| DELICIOUS 1500 SS DE | 1560x1000x840 | 119 | 12 | 28 | COD.34 |
| DELICIOUS 2000 SS DE | 2010x1000x840 | 139 | 8 | 20 | COD.34 |
| DELICIOUS 800 EURO-NORM C | 1360x1080x880 | 98 | 16 | 32 | COD.34 |
| DELICIOUS 1200 EURONORM C | 1360x1080x880 | 118 | 16 | 32 | COD.34 |
| ADRIATICA 900 | 1150x1150x1560 | 114 | 20 | 44 | |
| ADRIATICA 1300 | 1400x960x1115 | 135 | 16 | 32 | |
| ADRIATICA 1700 | 1800x960x1115 | 150 | 12 | 24 | |

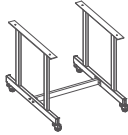
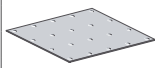
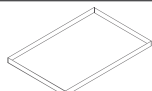
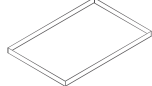
| Accessori - Accessories - Accessoires - Zuberhör - Accessorios | | MOD. |  Codice |
|--|----------------------|---------------------------|---|
|  Carrello / Trolley / Chariot / Wagen / Carro | | DELICIOUS 750 | 24301/01 |
| | | DELICIOUS 750 C | 24301/01 |
| | | DELICIOUS 750 C DE | 24301/01 |
| | | DELICIOUS 750 DE | 24301/01 |
| | | DELICIOUS 750 SS | 24301/01 |
| | | DELICIOUS 750 SS DE | 24301/01 |
| | | DELICIOUS 800 EURONORM C | 24301/01 |
| | | DELICIOUS 1000 | 21501/01 |
| | | DELICIOUS 1000 C | 21501/01 |
| | | DELICIOUS 1000 C DE | 21501/01 |
| | | DELICIOUS 1000 DE | 21501/01 |
| | | DELICIOUS 1000 SS | 21501/01 |
| | | DELICIOUS 1000 SS DE | 21501/01 |
| | | DELICIOUS 1200 EURONORM C | 21601/01 |
| | | DELICIOUS 1250 | 21601/01 |
| | | DELICIOUS 1250 C | 21601/01 |
| | | DELICIOUS 1250 C DE | 21601/01 |
| | | DELICIOUS 1250 DE | 21601/01 |
| | | DELICIOUS 1250 SS | 21601/01 |
| | | DELICIOUS 1250 SS DE | 21601/01 |
| | | DELICIOUS 1500 | 21601/01 |
| | | DELICIOUS 1500 C | 21601/01 |
| | | DELICIOUS 1500 C DE | 21601/01 |
| | | DELICIOUS 1500 DE | 21601/01 |
| | | DELICIOUS 1500 SS | 21601/01 |
| | | DELICIOUS 1500 SS DE | 21601/01 |
| | DELICIOUS 2000 | 34301/01 | |
| | DELICIOUS 2000 C | 34301/01 | |
| | DELICIOUS 2000 C DE | 34301/01 | |
| | DELICIOUS 2000 DE | 34301/01 | |
| | DELICIOUS 2000 SS | 34301/01 | |
| | DELICIOUS 2000 SS DE | 34301/01 | |

| Accessori - Accessories - Accessoires - Zuberhör - Accesorios | | MOD. | Codice |
|--|----------------------|---------------------------|----------|
|  <p>Carrello (ruote con e senza freno) / Trolley (wheels with and without brake) / Chariot (roues avec et sans frein) / Wagen (Räder mit und ohne Bremse) / Carro (ruedas con y sin freno)</p> | | DELICIOUS 750 | 24301/02 |
| | | DELICIOUS 750 C | 24301/02 |
| | | DELICIOUS 750 C DE | 24301/02 |
| | | DELICIOUS 750 DE | 24301/02 |
| | | DELICIOUS 750 SS | 24301/02 |
| | | DELICIOUS 750 SS DE | 24301/02 |
| | | DELICIOUS 800 EURONORM C | 24301/02 |
| | | DELICIOUS 1000 | 21501/02 |
| | | DELICIOUS 1000 C | 21501/02 |
| | | DELICIOUS 1000 C DE | 21501/02 |
| | | DELICIOUS 1000 DE | 21501/02 |
| | | DELICIOUS 1000 SS | 21501/02 |
| | | DELICIOUS 1000 SS DE | 21501/02 |
| | | DELICIOUS 1200 EURONORM C | 21601/02 |
| | | DELICIOUS 1250 | 21601/02 |
| | | DELICIOUS 1250 C | 21601/02 |
| | | DELICIOUS 1250 C DE | 21601/02 |
| | | DELICIOUS 1250 DE | 21601/02 |
| | | DELICIOUS 1250 SS | 21601/02 |
| | | DELICIOUS 1250 SS DE | 21601/02 |
| | | DELICIOUS 1500 | 21601/02 |
| | | DELICIOUS 1500 C | 21601/02 |
| | | DELICIOUS 1500 C DE | 21601/02 |
| | | DELICIOUS 1500 DE | 21601/02 |
| | | DELICIOUS 1500 SS | 21601/02 |
| | | DELICIOUS 1500 SS DE | 21601/02 |
| | DELICIOUS 2000 | 34301/02 | |
| | DELICIOUS 2000 C | 34301/02 | |
| | DELICIOUS 2000 C DE | 34301/02 | |
| | DELICIOUS 2000 DE | 34301/02 | |
| | DELICIOUS 2000 SS | 34301/02 | |
| | DELICIOUS 2000 SS DE | 34301/02 | |
|  <p>Piano inox forato / Stainless steel bored surface / Plan troué en acier inox / Gelochte Fläche aus rostfreiem Stahl / Plano perforado de acero inox</p> | | ADRIATICA 900 | ACP1113 |
| | | ADRIATICA 1300 | ACP1114 |
| | | ADRIATICA 1700 | X03365 |
| | | DELICIOUS 750 C DE | X03207 |
| | | DELICIOUS 750 DE | X03207 |
| | | DELICIOUS 750 SS DE | X03207 |
| | | DELICIOUS 1000 C DE | X03208 |
| | | DELICIOUS 1000 DE | X03208 |
| | | DELICIOUS 1000 SS DE | X03208 |
| | | DELICIOUS 1250 C DE | X03209 |
| | | DELICIOUS 1250 DE | X03209 |
| | | DELICIOUS 1250 SS DE | X03209 |
| | | DELICIOUS 1500 C DE | X03210 |
| | | DELICIOUS 1500 DE | X03210 |
| | | DELICIOUS 1500 SS DE | X03210 |
|  <p>Teglia in alluminio / Aluminium baking pan / Plat à rôtir en aluminium / Backform aus Aluminium / Bandeja para horno de aluminio</p> | | DELICIOUS 800 EURONORM C | E4301 |
| | | DELICIOUS 1200 EURONORM C | E4301 |
|  <p>Teglia inox / Stainless steel pan / Plaque inox / Inox-Backblech / Bandeja inox</p> | | DELICIOUS 800 EURONORM C | E4201 |
| | | DELICIOUS 1200 EURONORM C | E4201 |

| Optional - Optionnel - Extra - Extras | | MOD. |
|--|--|--|
|  <p>Supplemento per inversione porta / Supplement for door inversion / Supplément pour inversion de porte / Zuschlag für Türumkehrung / Suplemento para inversión de puertas</p> | | Per informazioni vi preghiamo di contattare il nostro ufficio commerciale / For information, please contact our export department / Pour informations, veuillez contacter notre service commercial / Für Informationen kontaktieren Sie bitte unsere Verkaufsabteilung / Si necesita información adicional, no dude en ponerse en contacto con nuestro departamento de venta |
|  <p>Supplemento per presa elettrica diversa dalla standard / Supplement for electric socket different than the standard / Supplément pour prise électrique différent de la norme / Aufpreis für Steckdose abweichend vom Standard / Suplemento para toma de corriente diferente al estándar</p> | | |

LINEE SHOPPING & COIBA



Vetrina refrigerata per pesce fresco, carne fresca e bacinelle GN / Refrigerated showcase for freshly-displayed fish, meat and GN boxes / Vitrine réfrigérée pour poisson frais, viande fraîche et plateaux GN / Gefrieres Schaufenster für Frischfisch, Frischfleisch und GN - Schüsseln / Vitrinas refrigeradas para pescado fresco y carne

MACELLERIA
 BUTCHER / BOUCHERIE
 METZGEREI / CARNICERIA

°C -1 / +6

PESCE FRESCO
 FRESH FISH / POISSON FRAIS
 FRISCHER FISCH / PESCADO FRESCO

°C -1 / +6

GASTRONOMIA
 GASTRONOMY / GASTRONOMIE
 DELICATESSEN / GASTRONOMIA

°C -1 / +6 • °C +30 / +70



SHOPPING 2700 COLD



ACCESSORIO / ACCESSORY:
 Montanti fissi in acciaio inox
 Non-removable stainless steel vertical rods
 Montants fixes en acier inoxydable
 Fixen Ständern aus rostfreiem Stahl
 Montantes fijos de acero inox

Neon di serie / Neon standard
 Néon standard / Neonlicht Standard
 Neón estándar

Portelli scorrevoli di chiusura
 Sliding doors
 Portes coulissantes de fermeture
 Verschiebbares Schließfach
 Puertas de cierre corredizas



SHOPPING 1400 COLD GN

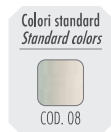

| | °C | Watt | m ² Superficie espositiva Display surface | DEFROST | H ₂ O | | | mm. (LxPxH) | Kg. | | | |
|-----------------------|-------|------|--|---------|------------------|--|------|--------------|-----|---|--------------|---|
| SHOPPING 1100 COLD | -1/+6 | 270 | 0,51 | | MAN | | R290 | 1072x960x615 | 102 | - | LED Standard | 1 |
| SHOPPING 1400 COLD | -1/+6 | 270 | 0,73 | | MAN | | R290 | 1394x960x615 | 125 | - | LED Standard | 1 |
| SHOPPING 2000 COLD | -1/+6 | 440 | 1,10 | | MAN | | R290 | 2038x960x615 | 165 | - | LED Standard | 1 |
| SHOPPING 2700 COLD | -1/+6 | 530 | 1,45 | | MAN | | R290 | 2682x960x615 | 245 | - | LED Standard | 1 |
| SHOPPING 1100 COLD GN | -1/+6 | 270 | 0,51 | | MAN | | R290 | 1072x960x615 | 102 | - | LED Standard | 1 |
| SHOPPING 1400 COLD GN | -1/+6 | 270 | 0,73 | | MAN | | R290 | 1394x960x615 | 125 | - | LED Standard | 1 |
| SHOPPING 2000 COLD GN | -1/+6 | 440 | 1,10 | | MAN | | R290 | 2038x960x615 | 165 | - | LED Standard | 1 |
| SHOPPING 2700 COLD GN | -1/+6 | 530 | 1,45 | | MAN | | R290 | 2682x960x615 | 245 | - | LED Standard | 1 |

Voltaggio di serie - Standard voltage: 230v/1/50Hz • Classe climatica - Climatic class: MAX = (25°C - % U.R. 60)

* Produzione a richiesta: per favore contattare l'ufficio commerciale / Production on request: please contact the sales dept.

Da appoggio su banco
To be positioned onto the counter
À positionner sur les étagères
Zum Aufsetzen auf den Ladentisch
Para colocar sobre el mostrador

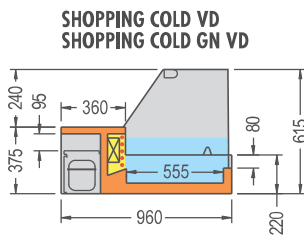
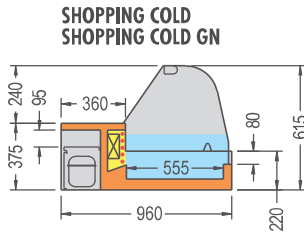

OPTIONAL:

Con montanti fissi in acc. inox
With non-removable stainless steel vertical rods
Avec montants fixes en acier inoxydable
Mit fixen Ständern aus rostfreiem Stahl
Con montantes fijos de acero inox

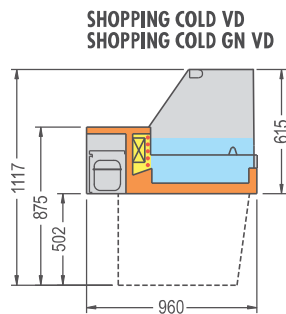
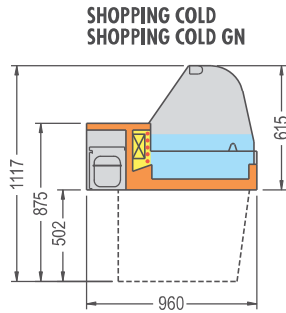

ACCESSORI / ACCESSORIES: Le vaschette GN sono fornite a richiesta / GN basins are available on request / Les bacs sont fournis su demande / Die Schalen werden auf Wunsch geliefert / Las cubetas se entregan bajo pedido

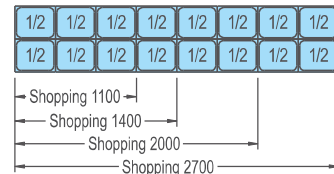
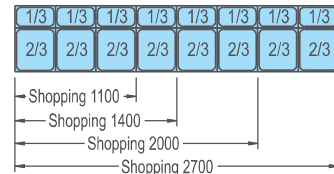
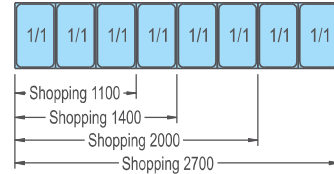

Vasca in acciaio inox AISI 316 resistente alla corrosione salina
Salt-proof AISI 316 stainless steel basin
Cuve en acier inox AISI 316 résistante à la corrosion du sel / Edelstahl AISI 316 Wanne Salzkorrosion resistent / Cuba en acero inox AISI 316 resistente a la corrosión salina

Sbrinatori nelle 24 h.
Defrosting in 24 h.
Dégivrages en 24 heures
Auftauen innerhalb 24 Stunden
Descongelación en las 24 h.
N° 4

Costruzione in acciaio inox 18/10
18/10 stainless steel body /
Construction en acier inoxydable 18/10
Konstruktion aus rostfreiem Stahl 18/10
Construcción de acero inoxidable 18/10

Mensola portaoggetti lato operatore
Object-holding top installed close to the operator / Étagère porte-objets côté opérateur / Konsole für verschiedene Gegenstände auf Technikersseite / Repisa para objetos al lado del operador

Copri evaporatore in acciaio inox
Stainless steel evaporator cover /
Dispositif de couverture de l'évaporateur en acier inoxydable / Verdampferabdeckung aus rostfreiem Stahl / Tapa del evaporador de acero inoxidable

Evaporatore trattato contro acidi
Anti-acid treated evaporator /
Évaporateur traité contre les acides /
Gegen Säuren behandelter Verdampfer /
Evaporador tratado con barnices anti-acidos

SHOPPING 1400 COLD VD



| | °C | Watt | m ² Superficie espositiva Display surface | DEFROST | H ₂ O | | mm. (LxPxH) | Kg. | | | |
|--------------------------|-------|------|--|---------|------------------|---|-------------------|-----|---|--------------|---|
| SHOPPING 1100 COLD VD | -1/+6 | 270 | 0,51 | ■ | MAN | ■ | R290 1072x960x615 | 102 | - | LED Standard | 1 |
| SHOPPING 1400 COLD VD | -1/+6 | 270 | 0,73 | ■ | MAN | ■ | R290 1394x960x615 | 125 | - | LED Standard | 1 |
| SHOPPING 2000 COLD VD | -1/+6 | 440 | 1,10 | ■ | MAN | ■ | R290 2038x960x615 | 165 | - | LED Standard | 1 |
| SHOPPING 2700 COLD VD | -1/+6 | 530 | 1,45 | ■ | MAN | ■ | R290 2682x960x615 | 245 | - | LED Standard | 1 |
| SHOPPING 1100 COLD GN VD | -1/+6 | 270 | 0,51 | ■ | MAN | ■ | R290 1072x960x615 | 102 | - | LED Standard | 1 |
| SHOPPING 1400 COLD GN VD | -1/+6 | 270 | 0,73 | ■ | MAN | ■ | R290 1394x960x615 | 125 | - | LED Standard | 1 |
| SHOPPING 2000 COLD GN VD | -1/+6 | 440 | 1,10 | ■ | MAN | ■ | R290 2038x960x615 | 165 | - | LED Standard | 1 |
| SHOPPING 2700 COLD GN VD | -1/+6 | 530 | 1,45 | ■ | MAN | ■ | R290 2682x960x615 | 245 | - | LED Standard | 1 |

Voltaggio di serie - Standard voltage: 230V/1/50Hz • Classe climatica - Climatic class: MAX = (25°C - % U.R. 60)

* Produzione a richiesta: per favore contattare l'ufficio commerciale / Production on request: please contact the sales dept.

SHOPPING 2000 DRY GN

Mensola portaoggetti lato operatore
 Object-holding top installed close to the operator
 Étagère porte-objets côté opérateur
 Konsole für verschiedene Gegenstände auf Technikerseite
 Repisa para objetos al lado del operador

Paralume con luce natura
 Natural light light-cover
 Pare-lumière avec lumière naturelle
 Leuchtschirm mit Naturlicht
 Tapa con luz natural

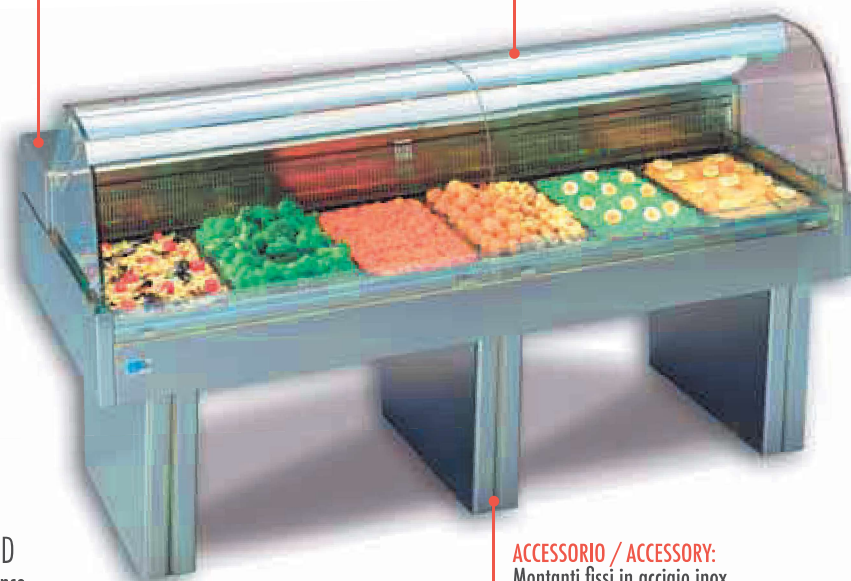

Portelli scorrevoli di chiusura
 Sliding doors
 Portes coulissantes de fermeture
 Verschiebbares Schließfach
 Puertas de cierre corredizas



Colori standard
 Standard colors

COD. 08

SHOPPING DRY GN VD

Versione da appoggio su banco
 Version to be positioned onto the counter
 Version à positionner sur les étagères
 Version zum Aufsetzen auf den Ladentisch
 Versión para colocar sobre el mostrador



ACCESSORIO / ACCESSORY:

Montanti fissi in acciaio inox
 Non-removable stainless steel vertical rods
 Montants fixes en acier inoxydable
 Fixen Ständern aus rostfreiem Stahl
 Montantes fijos de acero inox

Costruzione in acciaio inox 18/10
 18/10 stainless steel body
 Construction en acier inoxydable 18/10
 Konstruktion aus rostfreiem Stahl 18/10
 Construcción de acero inoxidable 18/10

Quadro elettronico lato operatore
 high-visibility and large-surface display top
 Panneau électronique côté opérateur
 Elektronischrank auf Technikerseite
 Cuadro electrónico del lado del operador

Vasca in acciaio inox AISI 316 resistente alla corrosione salina
 Salt-proof AISI 316 stainless steel basin
 Cuve en acier inox AISI 316 résistant à la corrosion du sel
 Edelstahl AISI 316 Wanne Salzkorrosion resistent
 Cuba en acero inox AISI 316 resistente a la corrosión salina

Le vaschette GN sono fornite a richiesta
 GN basins are available on request
 Les bacs sont fournis su demande
 Die Schalen werden auf Wunsch geliefert
 Los cubetas se entregan bajo pedido

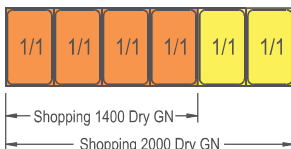

Da appoggio su banco
 To be positioned onto the counter
 À positionner sur les étagères
 Zum Aufsetzen auf den Ladentisch
 Para colocar sobre el mostrador

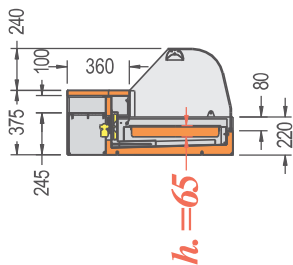

SHOPPING DRY GN VD

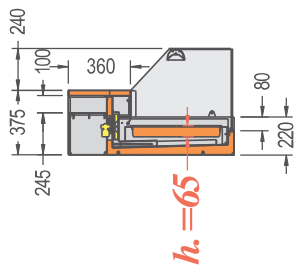

OPTIONAL:

Con montanti fissi in acc. inox
 With non-removable stainless steel vertical rods
 Avec montants fixes en acier inoxydable
 Mit fixen Ständern aus rostfreiem Stahl
 Con montantes fijos de acero inox

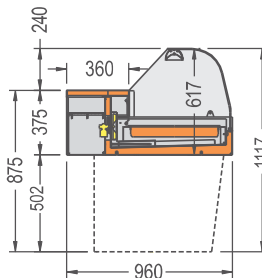

| | °C | Watt | m ² Superficie espositiva Display surface | mm. (LxPxH) | Kg. | | | |
|-------------------------|---------|------|--|--------------|-----|---|----------|---|
| SHOPPING 1400 DRY GN | +30/+70 | 3450 | 0,73 | 1394x960x615 | 125 | - | Standard | 1 |
| SHOPPING 2000 DRY GN | +30/+70 | 3550 | 1,10 | 2038x960x615 | 135 | - | Standard | 1 |
| SHOPPING 1400 DRY GN VD | +30/+70 | 3450 | 0,73 | 1394x960x615 | 125 | - | Standard | 1 |
| SHOPPING 2000 DRY GN VD | +30/+70 | 3550 | 1,10 | 2038x960x615 | 135 | - | Standard | 1 |

Voltaggio di serie - Standard voltage: 400v/3/50Hz

* Produzione a richiesta: per favore contattare l'ufficio commerciale / Production on request: please contact the sales dept.

COIBA 140 COLD

Paralume con luce
Light with light-cover
Pare-lumière avec lumière
Leuchtschirm mit licht
Tapa con luz

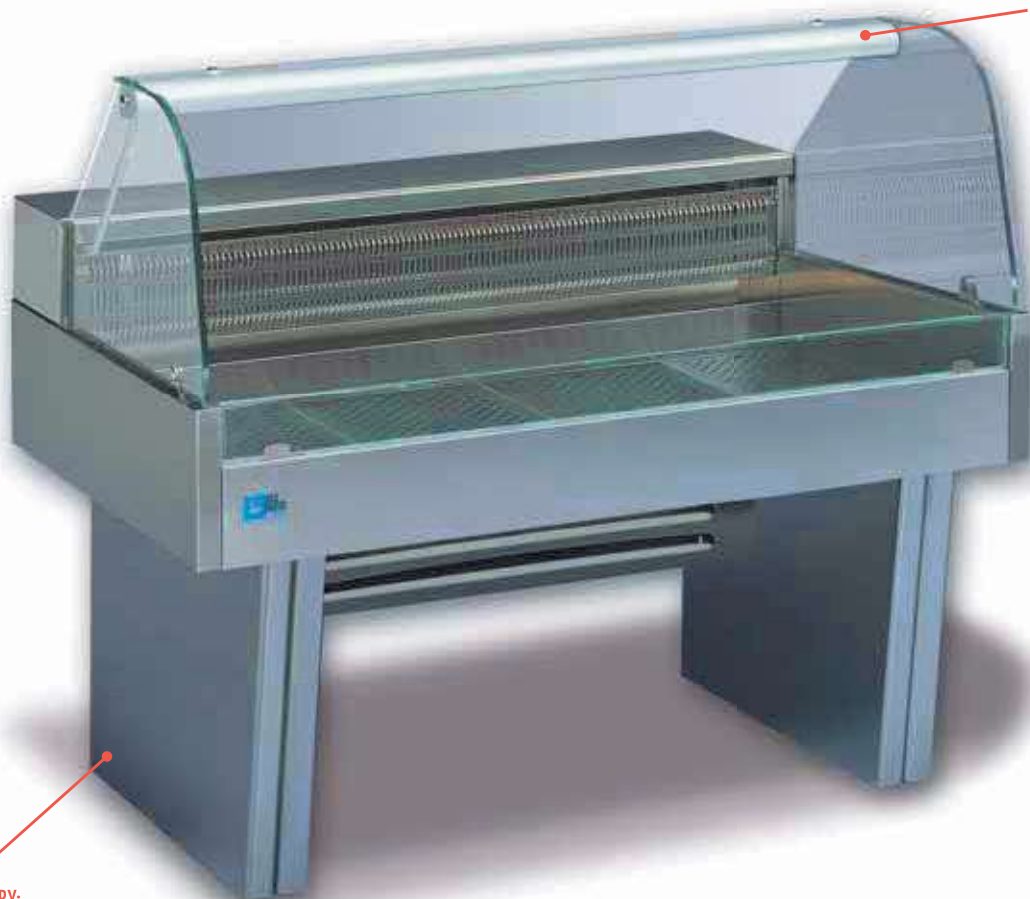

ACCESSORIO / ACCESSORY:
Montanti fissi in acciaio inox
Non-removable stainless steel vertical rods
Montants fixes en acier inoxydable
Fixen Ständer aus rostfreiem Stahl
Montantes fijos de acero inox

Portelli scorrevoli di chiusura
Sliding doors
Portes coulissantes de fermeture
Verschiebbares Schließfach
Puertas de cierre corredizas



COIBA 140 COLD VD



| | °C | Watt | m ² Superficie espositiva Display surface | DEFROST | H ₂ O | | | mm. (LxPxH) | Kg. | | | |
|-------------------|-------|------|--|---------|------------------|--|------|--------------|-----|---|--------------|---|
| COIBA 110 COLD | -1/+6 | 270 | 0,51 | | AUT | | R290 | 1072x780x895 | 102 | - | LED Standard | 1 |
| COIBA 140 COLD | -1/+6 | 270 | 0,73 | | AUT | | R290 | 1394x780x895 | 125 | - | LED Standard | 1 |
| COIBA 110 COLD GN | -1/+6 | 270 | 0,51 | | AUT | | R290 | 1072x780x895 | 102 | - | LED Standard | 1 |
| COIBA 140 COLD GN | -1/+6 | 270 | 0,73 | | AUT | | R290 | 1394x780x895 | 125 | - | LED Standard | 1 |

Voltaggio di serie - Standard voltage: 230v/1/50Hz • Classe climatica - Climatic class: MAX = (25°C - % U.R. 60)

Da appoggio su banco
To be positioned onto the counter
A positionner sur les étagères
Zum Aufsetzen auf den Ladentisch
Para colocar sobre el mostrador

**COIBA COLD
COIBA COLD GN**

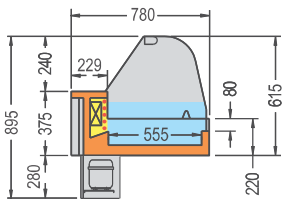

**COIBA COLD VD
COIBA COLD GN VD**

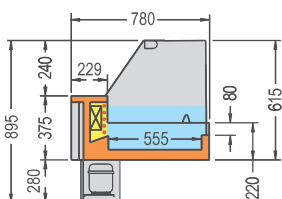

OPTIONAL:

Con montanti fissi in acc. inox
With non-removable stainless steel vertical rods
Avec montants fixes en acier inoxydable
Mit fixen Ständern aus rostfreiem Stahl
Con montantes fijos de acero inox

**COIBA COLD
COIBA COLD GN**

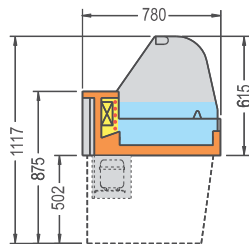

**COIBA COLD VD
COIBA COLD GN VD**

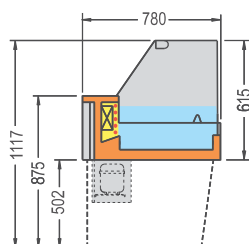

Sbrinatori nelle 24 h.
Defrosting in 24 h.
Dégivrages en 24 heures
Auftauen innerhalb 24 Stunden
Descongelación en las 24 h.
N° 4

Costruzione in acciaio inox 18/10
18/10 stainless steel body
Construction en acier inoxydable 18/10
Konstruktion aus rostfreiem Stahl 18/10
Construcción de acero inoxidable 18/10

Piano di esposizione di ampia superficie e maggiore visibilità
High-visibility and large-surface display top / Plan d'exposition de grandes dimensions et de grande visibilité / Große und besser sichtliche Ausstellfläche / Importante plano de exposición y de muy buena visibilidad

Mensola portaoggetti lato operatore
Object-holding top installed close to the operator / Étagère porte-objets côté opérateur / Konsole für verschiedene Gegenstände auf Technikerseite / Repisa para objetos al lado del operador

Copri evaporatore in acciaio inox
Stainless steel evaporator cover / Dispositif de couverture de l'évaporateur en acier inoxydable / Verdampferabdeckung aus rostfreiem Stahl / Tapa del evaporador de acero inoxidable

Evaporatore trattato contro acidi
Anti-acid treated evaporator / Évaporateur traité contre les acides / Gegen Säuren behandelter Verdampfer / Evaporador tratado con barnices anti-acidos

ACCESSORI / ACCESSORIES: Le vaschette GN sono fornite a richiesta / GN basins are available on request / Les bacs sont fournis su demande / Die Schalen werden auf Wunsch geliefert / Los cubetas se entregan bajo pedido

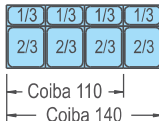

COIBA 140 GN COLD

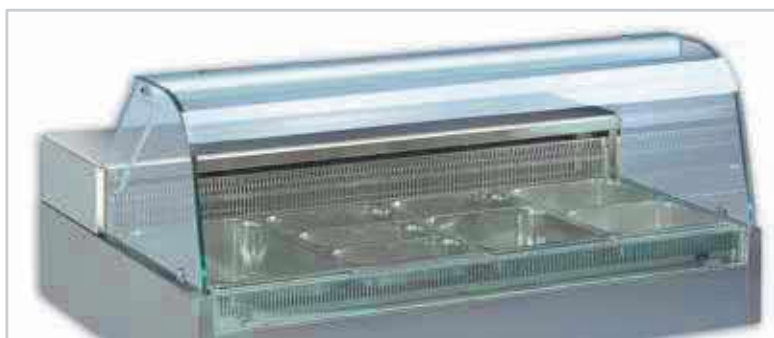

COIBA 140 COLD

Vasca in acciaio inox AISI 316 resistente alla corrosione salina
Salt-proof AISI 316 stainless steel basin / Cuve en acier inox AISI 316 résistant à la corrosion du sel / Edelstahl AISI 316 Wanne Salzkorrosion resistent / Cuba en acero inox AISI 316 resistente a la corrosión salina



| | °C | Watt | m ² Superficie espositiva Display surface | DEFROST | H ₂ O | | mm. (LxPxH) | Kg. | | | | |
|----------------------|-------|------|--|---------|------------------|---|-------------|--------------|-----|---|--------------|---|
| COIBA 110 COLD VD | -1/+6 | 270 | 0,51 | ■ | AUT | ■ | R290 | 1072x780x895 | 102 | - | LED Standard | 1 |
| COIBA 140 COLD VD | -1/+6 | 270 | 0,73 | ■ | AUT | ■ | R290 | 1394x780x895 | 125 | - | LED Standard | 1 |
| COIBA 110 COLD GN VD | -1/+6 | 270 | 0,51 | ■ | AUT | ■ | R290 | 1072x780x895 | 102 | - | LED Standard | 1 |
| COIBA 140 COLD GN VD | -1/+6 | 270 | 0,73 | ■ | AUT | ■ | R290 | 1394x780x895 | 125 | - | LED Standard | 1 |

Voltaggio di serie - Standard voltage: 230v/1/50Hz • Classe climatica - Climatic class: MAX = (25°C - % U.R. 60)

Vetrina frigorifera per pesce / Refrigerated fish cabinet / Vitrine réfrigérée pour poisson / Fischvitrine / Vitrina frigorífica para pescado

OCEANUS 150



Paralume con luce / Light with light-cover
Pare-lumière avec lumière / Leuchtschirm mit licht
Tapa con luz

OCEANUS
OCEANUS C

Chiusura posteriore con porte scorrevoli in Plexiglas / Back closure with sliding Plexiglas doors / Fermeture arrière avec portes coulissantes en Plexiglas / Rückseitiger Verschluss mit Schiebetüren aus Plexiglas / Cierre trasero con puertas corredizas de Plexiglas

Costruzione in acciaio inox 18/10 AISI 304 / 18/10 AISI 304 stainless steel body / Construction en acier inoxydable 18/10 AISI 304 / Konstruktion aus rostfreiem Stahl 18/10 AISI 304 / Construcción de acero inoxidable 18/10 AISI 304

Vasca in acciaio inox AISI 316 resistente alla corrosione salina / Salt-proof AISI 316 stainless steel basin / Cuve en acier inox AISI 316 résistant à la corrosion du sel / Edelstahl AISI 316 Wanne Salzkorrosion resistent / Cuba en acero inox AISI 316 resistente a la corrosión salina

Vano frigorifero chiuso con riserva neutra / Closed refrigerator cupboard with non-refrigerated unit / Logement réfrigéré fermé avec tiroir de rangement / Geschlossener Kühlraum mit ungekühltem Behälter / Alojamiento frigorífico cerrado con contenedor de reserva neutro (no refrigerado)



Spontabile su ruote / Showcase on wheels
Se manutentionne sur chariot / Fahrbar / Sobre ruedas

Griglia in Aisi 304 / Aisi 304 grille
Grille en Aisi 304 / Aisi 304-Roste / Rejilla de Aisi 304



OCEANUS 100
OCEANUS 150

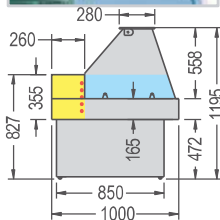

OCEANUS 100 C
OCEANUS 150 C

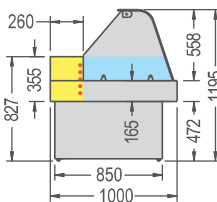

OCEANUS 100 SS
OCEANUS 150 SS

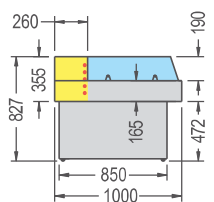

OCEANUS 100 SS





| | °C | Watt | m ² Superficie espositiva Display surface | DEFROST | H ₂ O | | | mm. (LxPxH) | Kg. | | | |
|----------------|----|------|--|---------|------------------|--|------|----------------|-----|---|--------------|---|
| OCEANUS 100 | -2 | 370 | 0,64 | | MAN | | R290 | 1000x1000x1195 | 128 | - | LED Standard | 1 |
| OCEANUS 100 C | -2 | 370 | 0,64 | | MAN | | R290 | 1000x1000x1195 | 128 | - | LED Standard | 1 |
| OCEANUS 100 SS | -2 | 370 | 0,64 | | MAN | | R290 | 1000x1000x827 | 95 | - | - | 1 |
| OCEANUS 150 | -2 | 465 | 0,99 | | MAN | | R290 | 1500x1000x1195 | 158 | - | LED Standard | 1 |
| OCEANUS 150 C | -2 | 465 | 0,99 | | MAN | | R290 | 1500x1000x1195 | 158 | - | LED Standard | 1 |
| OCEANUS 150 SS | -2 | 465 | 0,99 | | MAN | | R290 | 1500x1000x827 | 123 | - | - | 1 |

Voltaggio di serie - Standard voltage: 230V/1/50Hz • Classe climatica - Climatic class: MAX = (30°C - % U.R. 55)

* Produzione a richiesta: per favore contattare l'ufficio commerciale / Production on request: please contact the sales dept.

| MOD. | LxPxH mm | Kg |  | | colore colour color |
|--------------------------|---------------|-----|---|----------------------|---------------------------|
| | | | container n°(20') | container n°(40') | |
| SHOPPING 1100 COLD | 1130x1050x740 | 127 | 30 | 60 | COD.08 |
| SHOPPING 1400 COLD | 1470x1050x740 | 150 | 18 | 48 | COD.08 |
| SHOPPING 2000 COLD | 2130x1050x740 | 205 | 12 | 30 | COD.08 |
| SHOPPING 2700 COLD | 2770x1050x740 | 295 | 12 | 24 | COD.08 |
| SHOPPING 1100 COLD GN | 1130x1050x740 | 127 | 30 | 60 | COD.08 |
| SHOPPING 1400 COLD GN | 1470x1050x740 | 150 | 18 | 48 | COD.08 |
| SHOPPING 2000 COLD GN | 2130x1050x740 | 205 | 12 | 30 | COD.08 |
| SHOPPING 2700 COLD GN | 2770x1050x740 | 295 | 12 | 24 | COD.08 |
| SHOPPING 1100 COLD VD | 1130x1050x740 | 127 | 30 | 60 | COD.08 |
| SHOPPING 1400 COLD VD | 1470x1050x740 | 150 | 18 | 48 | COD.08 |
| SHOPPING 2000 COLD VD | 2130x1050x740 | 205 | 12 | 30 | COD.08 |
| SHOPPING 2700 COLD VD | 2770x1050x850 | 295 | 12 | 24 | COD.08 |
| SHOPPING 1100 COLD GN VD | 1130x1050x740 | 127 | 30 | 60 | COD.08 |
| SHOPPING 1400 COLD GN VD | 1470x1050x740 | 150 | 18 | 48 | COD.08 |
| SHOPPING 2000 COLD GN VD | 2130x1050x740 | 205 | 12 | 30 | COD.08 |
| SHOPPING 2700 COLD GN VD | 2770x1050x850 | 295 | 12 | 24 | COD.08 |
| SHOPPING 1400 DRY GN | 1470x1050x740 | 150 | 18 | 48 | COD.08 |



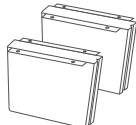





| MOD. | LxPxH mm | Kg |  | | colore colour color |
|-------------------------|----------------|-----|---|----------------------|---------------------------|
| | | | container n°(20') | container n°(40') | |
| SHOPPING 2000 DRY GN | 2130x1050x740 | 175 | 12 | 30 | COD.08 |
| SHOPPING 1400 DRY GN VD | 1470x1050x740 | 150 | 18 | 48 | COD.08 |
| SHOPPING 2000 DRY GN VD | 2130x1050x740 | 175 | 12 | 30 | COD.08 |
| COIBA 110 COLD | 1355x1080x880 | 127 | 16 | 32 | COD.08 |
| COIBA 140 COLD | 1560x1000x880 | 150 | 12 | 28 | COD.08 |
| COIBA 110 COLD GN | 1355x1080x880 | 127 | 16 | 32 | COD.08 |
| COIBA 140 COLD GN | 1560x1000x880 | 150 | 12 | 28 | COD.08 |
| COIBA 110 COLD VD | 1355x1080x880 | 127 | 16 | 32 | COD.08 |
| COIBA 140 COLD VD | 1560x1000x880 | 150 | 12 | 28 | COD.08 |
| COIBA 110 COLD GN VD | 1355x1080x880 | 127 | 16 | 32 | COD.08 |
| COIBA 140 COLD GN VD | 1560x1000x880 | 150 | 12 | 28 | COD.08 |
| OCEANUS 100 | 1070x1070x1130 | 150 | 20 | 44 | COD.08 |
| OCEANUS 100 C | 1070x1070x1130 | 150 | 20 | 44 | COD.08 |
| OCEANUS 100 SS | 1070x1070x1130 | 120 | 20 | 44 | COD.08 |
| OCEANUS 150 | 1570x1070x1130 | 183 | 12 | 28 | COD.08 |
| OCEANUS 150 C | 1570x1070x1130 | 183 | 12 | 28 | COD.08 |
| OCEANUS 150 SS | 1570x1070x1130 | 148 | 12 | 28 | COD.08 |

| Accessori - Accessories - Accessoires - Zuberhör - Accesorios | | MOD. |  Codice |
|--|--------------------------|--------------------------|---|
|  <p>Montanti fissi in acciaio inox / Stainless steel non-moving pillar / Montants fixes en acier inoxydable / Pfosten aus rostfreiem Stahl / Montantes fijos de acero inoxidable</p> | | COIBA 110 COLD | 27901/02 |
| | | COIBA 110 COLD GN | 27901/02 |
| | | COIBA 110 COLD GN VD | 27901/02 |
| | | COIBA 110 COLD VD | 27901/02 |
| | | COIBA 140 COLD | 27901/02 |
| | | COIBA 140 COLD GN | 27901/02 |
| | | COIBA 140 COLD GN VD | 27901/02 |
| | | COIBA 140 COLD VD | 27901/02 |
| | | SHOPPING 1100 COLD | 27901/02 |
| | | SHOPPING 1100 COLD GN | 27901/02 |
| | | SHOPPING 1100 COLD GN VD | 27901/02 |
| | | SHOPPING 1100 COLD VD | 27901/02 |
| | | SHOPPING 1400 COLD | 27901/02 |
| | | SHOPPING 1400 COLD GN | 27901/02 |
| | | SHOPPING 1400 COLD GN VD | 27901/02 |
| | | SHOPPING 1400 COLD VD | 27901/02 |
| | | SHOPPING 1400 DRY GN | 27901/02 |
| | | SHOPPING 1400 DRY GN VD | 27901/02 |
| | | SHOPPING 2000 COLD | 28001/02 |
| | | SHOPPING 2000 COLD GN | 28001/02 |
| | | SHOPPING 2000 COLD GN VD | 28001/02 |
| | | SHOPPING 2000 COLD VD | 28001/02 |
| | | SHOPPING 2000 DRY GN | 28001/02 |
| | | SHOPPING 2000 DRY GN VD | 28001/02 |
| | | SHOPPING 2700 COLD | 28001/02 |
| | SHOPPING 2700 COLD GN | 28001/02 | |
| | SHOPPING 2700 COLD GN VD | 28001/02 | |
| | SHOPPING 2700 COLD VD | 28001/02 | |

 **ACCESSORI BACINELLE E COPERCHI INOX:** verificare capacità e composizione a catalogo. Pag. 569 / **ACCESSORIES STAINLESS STEEL BASINS AND LIDS:** please verify the capacity and composition in the catalogue. Page 569 / **ACCESSOIRES BACS ET COUVERCLES EN INOX:** vérifier la capacité et la composition dans le catalogue. Page 569 / **ZUBEHÖR INOX SCHALEN UND DECKEL:** überprüfen Sie Kapazität und Zusammensetzung im Katalog. Seite 569 / **ACCESORIOS CUBETAS Y TAPAS INOX:** ver capacidad y composición en el catálogo. Pag. 569

| Optional - Optionnel - Extra - Extras | | MOD. |
|--|--|--|
|  <p>Supplemento per presa elettrica diversa dalla standard / Supplement for electric socket different than the standard / Supplément pour prise électrique différent de la norme / Aufpreis für Steckdose abweichend vom Standard / Suplemento para toma de corriente diferente al estándar</p> | | Per informazioni vi preghiamo di contattare il nostro ufficio commerciale / For information, please contact our export department / Pour informations, veuillez contacter notre service commercial / Für Informationen kontaktieren Sie bitte unsere Verkaufsabteilung / Si necesita información adicional, no dude en ponerse en contacto con nuestro departamento de venta |

Bacinelle e vaschette inox / Stainless steel basins

| Bacinelle e coperchi inox per gastronomia calda / Stainless steel basins and lids for heated gastronomy / Bacs et couvercles inox pour gastronomie chaude / Schalen und Deckel aus Edelstahl für warme Speisen / Cubetas y tapas inox para gastronomia caliente | |  | |
|---|---|---|---------|
| | | Codice | |
|  | Coperchi inox per bacinelle con manici / Stainless steel lids for basins with handles / Couvercles en acier inox pour bacs avec manches / Deckel aus Nirostahl für Schalen mit Griffen / Tapas de acero inox para cubetas con tirador | COPERCHIO INOX GN 1/1 | C8802 |
| | | COPERCHIO INOX GN 1/2 | C8804 |
| | | COPERCHIO INOX GN 1/3 | C8805 |
| | | COPERCHIO INOX GN 1/4 | C8806 |
| | | COPERCHIO INOX GN 2/3 | C8803 |
|  | Bacinella inox con manici / Inox basin with handles / Bac en inox avec manches / Behälter aus Nirostahl mit Griffen / Cubeta de acero inox con tirador | VASCETTA INOX 1/1 H=65 C/MAN | C8709 |
| | | VASCETTA INOX 1/1 H=150 C/MAN | C8702 |
| | | VASCETTA INOX 1/2 H=150 C/MAN | C8704 |
| | | VASCETTA INOX 1/3 H=150 C/MAN | C8705 |
| | | VASCETTA INOX 1/4 H=150 C/MAN | C8706 |
| | | VASCETTA INOX 2/1 H=150 C/MAN | C8701 |
| | | VASCETTA INOX 2/3 H=150 C/MAN | C8703 |
| Bacinelle e coperchi inox per gastronomia fredda / Stainless steel basins and lids for cold gastronomy / Bacs et couvercles inox pour gastronomie froide / Schalen und Deckel aus Edelstahl für kalte Speisen / Cubetas y tapas inox para gastronomia fría | |  | |
| | | Codice | |
|  | Coperchi inox per bacinelle / Stainless steel lids for basins / Couvercles en acier inox pour bacs / Deckel aus Nirostahl für Schalen / Tapas de acero inox para cubetas | COPERCHIO INOX X GN 1/1 | D3601 |
| | | COPERCHIO INOX X GN 1/2 | D3602 |
| | | COPERCHIO INOX X GN 1/3 | D3603 |
| | | COPERCHIO INOX X GN 1/4 | D3604 |
| | | COPERCHIO INOX X GN 1/6 | D3605 |
| | | COPERCHIO INOX X GN 1/9 | D3607 |
| | | COPERCHIO INOX X GN 2/3 | D3606 |
|  | Bacinella inox / Inox basin / Bac en inox / Behälter aus Nirostahl / Cubeta de acero inox | VASSOIO INOX G.N. 1/1 H20 | E4002 |
| | | VASSOIO INOX G.N. 2/1 H20 | E4001 |
| | | VASCETTA INOX GN 2/3 - H. 20 MM. | E4003 |
| | | VASCETTA INOX 1/1 H=40 | E4502 |
| | | VASCETTA INOX GN 1/2 - H. 40 MM. | E4504 |
| | | VASCETTA INOX 1/3 H=40 | E4506 |
| | | VASCETTA INOX GN 1/4 - H. 40 MM. | E4505 |
| | | VASCETTA INOX GN 2/1 - H. 40 MM. | E4501 |
| | | VASCETTA INOX GN 2/3 - H. 40 MM. | E4503 |
| | | VASCETTA INOX 1/1 H=65 | A8302 |
| | | VASCETTA INOX 1/2 H=65 | A8301 |
| | | VASCETTA INOX 1/3 H=65 | A8305 |
| | | VASCETTA INOX 2/3 H=65 | A8304 |
| | | VASCETTA INOX 1/1 H=100 | C0102 |
| | | VASCETTA INOX 1/2 H=100 | C0104 |
| | | VASCETTA INOX 1/3 H=100 | C0105 |
| | | VASCETTA INOX 1/4 H=100 | C0106 |
| | | VASCETTA INOX 1/6 H=100 | C0107 |
| | | VASCETTA INOX 1/9 H=100 | C0108 |
| | | VASCETTA INOX 2/1 H=100 | C0101 |
| | | VASCETTA INOX 2/3 H=100 | C0103 |
| | | VASCETTA INOX 1/1 H=150 | C0202 |
| | | VASCETTA INOX 1/2 H=150 | C0204 |
| | | VASCETTA INOX 1/3 H=150 | C0205 |
| | | VASCETTA INOX 1/4 H=150 | C0206 |
| | | VASCETTA INOX 1/6 H=150 | C0207 |
| VASCETTA INOX 2/1 H=150 | C0201 | | |
| VASCETTA INOX 2/3 H=150 | C0203 | | |
| Vaschetta inox per gelato / Stainless steel basins for icecream / Bacs à glace en acier inoxydable / Rostfreie Schalen für Eis / Cubetas de acero inoxidable para helado | |  | |
| | | Codice | |
|  | Vaschetta inox per gelato / Stainless steel basin for icecream / Bac à glace en acier inoxydable / Rostfreie Schalen für Eis / Cubeta de acero inoxidable para helado | VASCETTA INOX 180X165X126 LT 2.5 | B251701 |
| | | VASCETTA INOX 258X156X170 LT 4.5 | A8501 |
| | | VASCETTA INOX 360X165X120 LT 5 | A8505 |
| | | VASCETTA INOX 360X165X150 LT 7 | A8507 |
| | | VASCETTA INOX 360X165X180 LT 9 | A8510 |
| | | VASC. INOX 360X250X80 LT 7 | A8516 |
| | | VASCH. INOX 360X250X120 LITRI 10 | A8506 |
| | | VASCETTA INOX 360X250X150 LT 12 | A8515 |
| | | VASCETTA INOX 360X250X180 LT 14 | A8511 |

